

- Axialstechwerkzeuge, speziell für Einstiche bei Werkstücken mit Bund.
- Stechbreiten von 1 bis 3mm
- Stechtiefen bis max. 5mm in Abhängigkeit zur Stechbreite.
- Kleinster Nut-Aussendurchmesser = 12 mm.

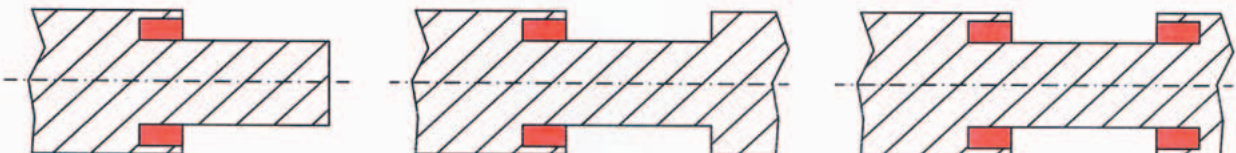

Grundhalter D14. ... STL

Artikel-Nr. order no.	H [mm]	B [mm]	L [mm]	F [mm]	Ersatzteile Schraube
D14.1212.STL	12,0	12,0	100,0	2,0	DM4x12T15F
D14.1616.STL	16,0	16,0	125,0	6,0	DM4x12T15F
D14.2020.STL	20,0	20,0	125,0	10,0	DM4x12T15F
D14.2525.STL	25,0	25,0	150,0	15,0	DM4x12T15F

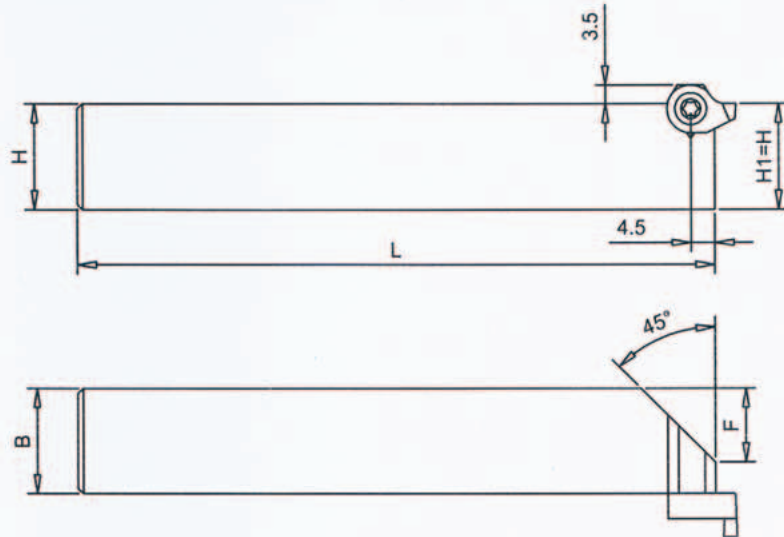
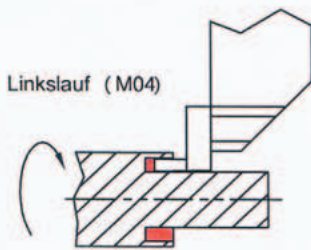

Schneideinsätze D14. ... AR

Artikel-Nr. order no.	Lieferstatus / stock		b (mm)	tmax (mm)	f (mm)	a (mm)	R (mm)	S (mm)
	GX75 -308	ZGX40 -314						
D14.1210.00AR	⊙	⊙	1,0	1,50	7,0	11,5	-	8,3
D14.1215.02AR	⊙	⊙	1,5	2,50	7,5	12,0	0,2	8,3
D14.1220.02AR	⊙	⊙	2,0	3,00	8,0	12,5	0,2	8,3
D14.1225.02AR	⊙	⊙	2,5	3,00	8,5	13,0	0,2	8,3
D14.1230.02AR	⊙	⊙	3,0	3,00	9,0	13,5	0,2	8,3
D14.1220.52AR	⊙	⊙	2,0	5,00	8,0	12,5	0,2	10,3
D14.1225.52AR	⊙	⊙	2,5	5,00	8,5	13,0	0,2	10,3
D14.1230.52AR	⊙	⊙	3,0	5,00	9,0	13,5	0,2	10,3

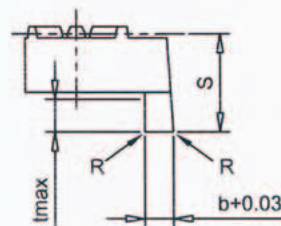
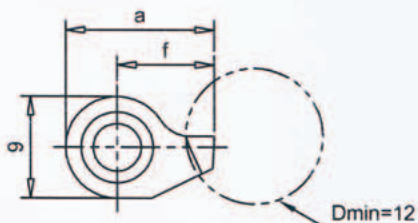

Grundhalter D14. ... STR

Artikel-Nr. order no.	H [mm]	B [mm]	L [mm]	F [mm]	Ersatzteile Schraube
D14.1212.STR	12,0	12,0	100,0	2,0	DM4x12T15F
D14.1616.STR	16,0	16,0	125,0	6,0	DM4x12T15F
D14.2020.STR	20,0	20,0	125,0	10,0	DM4x12T15F
D14.2525.STL	25,0	25,0	150,0	15,0	DM4x12T15F

Rechtslauf (M03)

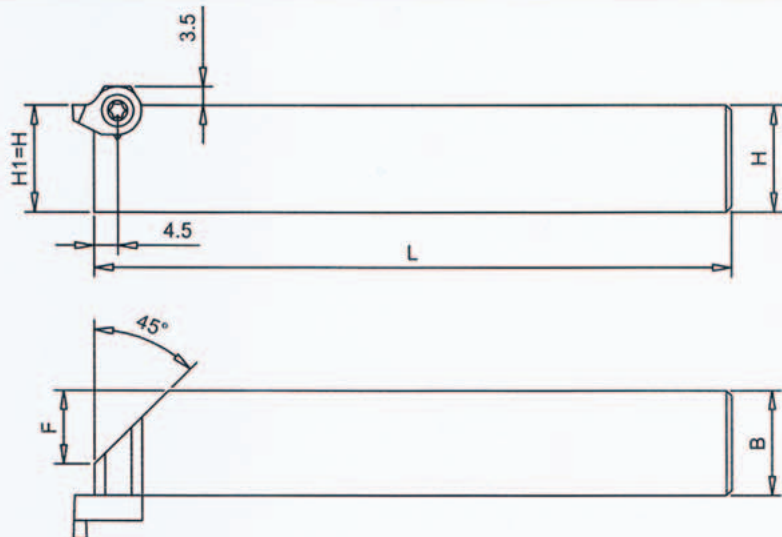
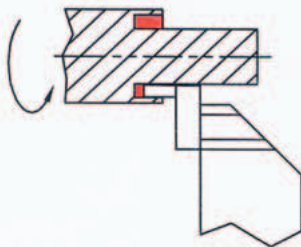

Schneideinsätze D14. ... AL

Artikel-Nr. order no.	Lieferstatus / stock		b (mm)	tmax (mm)	f (mm)	a (mm)	R (mm)	S (mm)
	GX75 -308	ZGX40 -314						
D14.1210.00AL	⊙	⊙	1,0	1,50	7,0	11,5	-	8,3
D14.1215.02AL	⊙	⊙	1,5	2,50	7,5	12,0	0,2	8,3
D14.1220.02AL	⊙	⊙	2,0	3,00	8,0	12,5	0,2	8,3
D14.1225.02AL	⊙	⊙	2,5	3,00	8,5	13,0	0,2	8,3
D14.1230.02AL	⊙	⊙	3,0	3,00	9,0	13,5	0,2	8,3
D14.1220.52AL	⊙	⊙	2,0	5,00	8,0	12,5	0,2	10,3
D14.1225.52AL	⊙	⊙	2,5	5,00	8,5	13,0	0,2	10,3
D14.1230.52AL	⊙	⊙	3,0	5,00	9,0	13,5	0,2	10,3

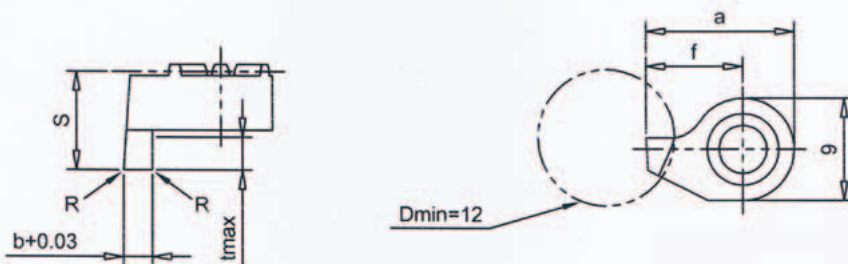



ZINNER GmbH Präzisions-Werkzeugfabrik

Postfach 84 01 53 - 90257 Nürnberg - Germany - Tel. (0911) 939 739-0 - Fax (0911) 3 26 23 89

Internet: <http://www.zinner.com> - e-Mail: info@zinner.com
