

Bearbeitungsbeispiel: Adapterstück (Hydraulik/Pneumatik)

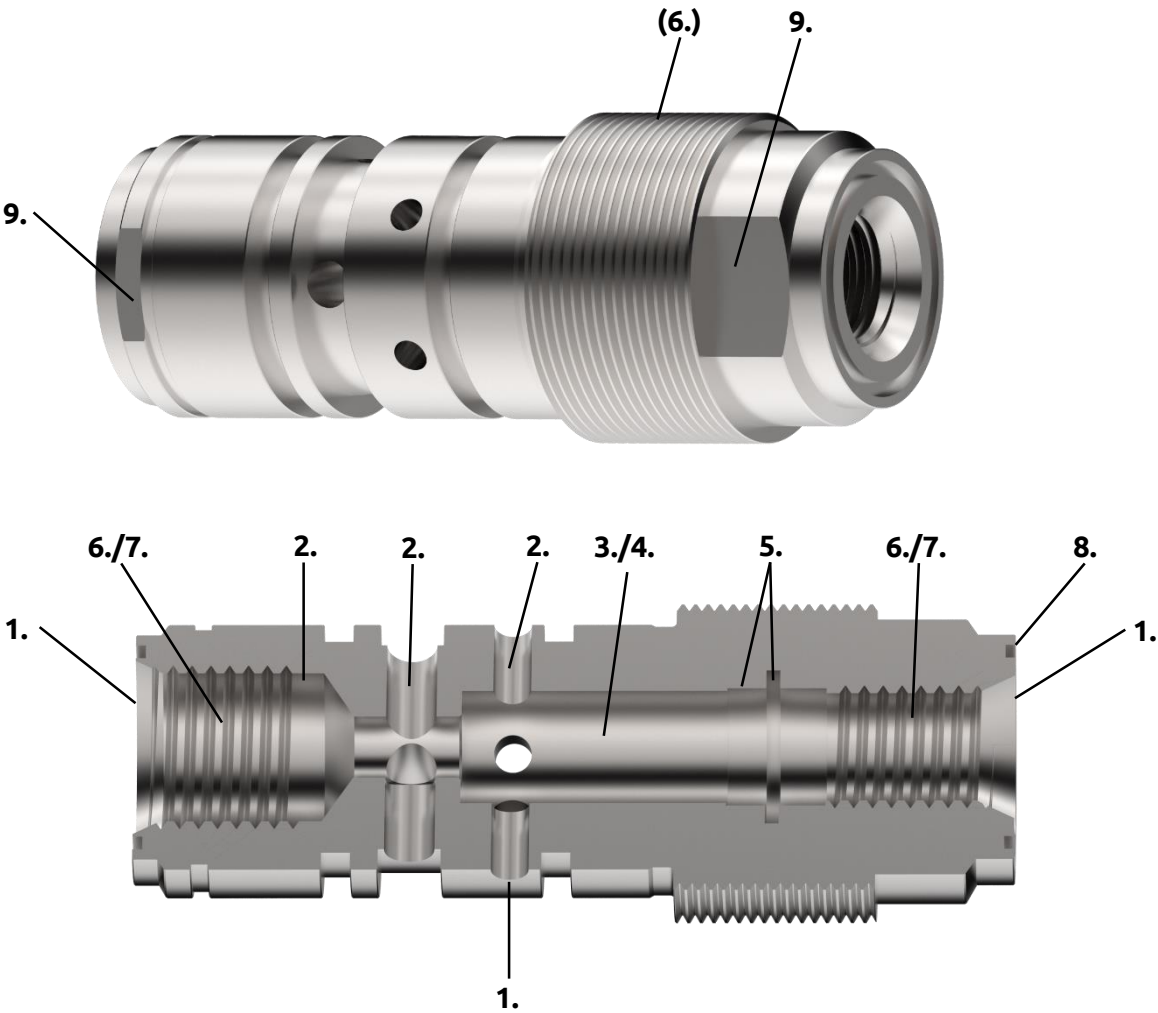

1. DRP - Punktanbohrer



2. DRA - Hochleistungs-Anfasbohrer



3. SDG - Bohrstange



4. DRE - Präzisions Reibwerkzeug oder Stufenreibahle



5. SDS - Innen-Einsteckstahl



6. SDU/SDV - Gewindestahl mit Teil- / Vollprofil



7. WHC/WHS - Gewindewirbler



8. SXP - Stirn-Einsteckstahl



9. Werkzeuge zur Herstellung von speziellen Profilen auf Kundenwunsch

