

Werkzeughalter für CNC-Drehmaschinen DIN 69880 / DIN ISO 10889

Toolholders for CNC machines
DIN 69880 / DIN ISO 10889

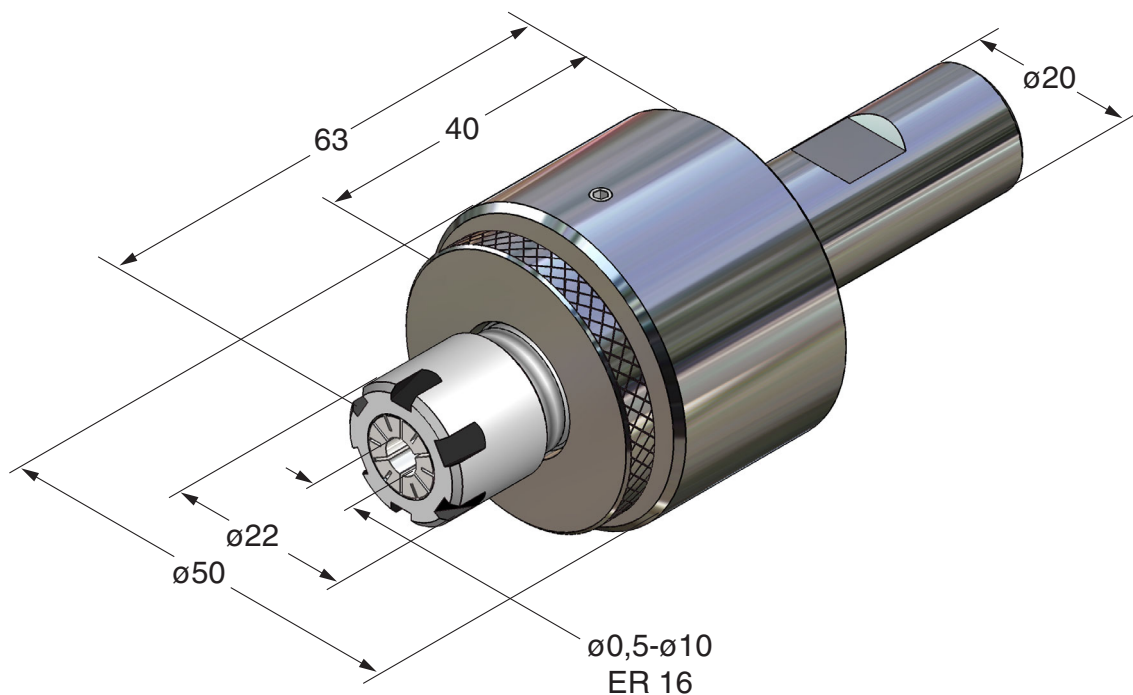

Pendelhalter, achsparallel ausgleichend einstellbar
Floating toolholder, axially parallel compensating



Art.-Nr.	Typ
20.70.351	20xER16mx63

