

Steilkegel-Werkzeugaufnahmen DIN 69871 MAS BT DIN 2080

ISO Taper-toolholders
DIN 69871 MAS BT DIN 2080



Katalog Nr. 166
Catalogue No. 166



Produktgruppen Product groups	Seite Page
.....
Technische Daten Technical Data	4
Werkzeugaufnahmen MAS BT 15 ISO Taper-toolholders MAS BT 15	5
Werkzeugaufnahmen BT-P30 + BT-P40 mit Plananlage ISO Taper-toolholders BT-P30 + BT-P40 with flange contact	6-10
Spannzangenfutter MAS BT15-BT30 - ER16 / ETS16 Collet chucks MAS BT15-BT30 - ER16 / ETS16	11
Spannzangenfutter BT30 radial feinverstellbar Collet chucks BT30 radially adjustable	12-13
Spannzangenfutter DIN 6391 ohne Mitnehmernut Collet chucks DIN 6391 without groove	14
Pendelhalter & Einsätze Floating holders & inserts	15
Spannzangenfutter für Spannzangen ER/ESX DIN 6499 / ISO 15488 Collet chucks for collets ER/ESX DIN 6499 / ISO 15488	16
Spannzangenfutter für Spannzangen DIN 6388 / ISO 10897 Collet chucks for collets DIN 6388 / ISO 10897	17
Kombiaufsteckfräsdorne DIN 6358 Universal arbors DIN 6358	18
Messerkopfaufnahmen DIN 6357 Shell mill adapter for facing cutters DIN 6357	19
Zylinderschaftaufnahmen Weldon DIN 1835 B Holders for straight shank tools Weldon DIN 1835 B	20-22
Zylinderschaftaufnahmen Whistle Notch DIN 1835 E / Zubehör Holders for straight shank tools Whistle Notch DIN 1835 E / Accessories	23-24
NC-Bohrfutter für Rechts- und Linkslauf / Bohrfutteraufnahmen DIN 238 CNC-Drill chucks for clockwise and anti-clockwise rotation / Drill chuck arbor DIN 238	25

Allgemeine Verkaufsbedingungen finden Sie auf unserer Website:

Visit our website for General Condition of Sales:

www.zuern-tools.de/agb

Produktgruppen Product groups	Seite Page
Schrumpffutter Shrinking chucks	26–29
Dehnspannfutter / Zwischenhülsen Expansion chucks / Sleeves	30
Werkzeugaufnahmen zur Kühlmittel- bzw. Luftzufuhr Toolholders for coolant- and air-supply	31
Gewindeschneidfutter für Spannzangen Tapping heads for collets	32
Gewindeschneid-Schnellwechselfutter / Einsätze Thread cutting quick-change chucks	33
Aufnahmen für Einschraubfräser Adaptors for end mills with thread shank	34
Kegelhülsen MK DIN 228 Form A / Form B Reducing adaptors MT DIN 228 form A / form B	35
Stellhülsen aufnahmen nach DIN 6327 / Adapter für HSK DIN 69893 Adaptors for setting sleeves to DIN 6327 / Adaptors for HSK DIN 69893	36
Einstelldorn in Holzetui / Rohlinge Control arbor in wooden case / Blanks	37
Steilkegel-Werkzeugaufnahmen DIN 2080 Iso taper-toolholders DIN 2080	38–42
Anzugsbolzen Retention knobs	43
Spannmuttern / Zubehör & Ersatzteile Clamping nuts / Accessories and spare parts	44–46
Dichtscheiben Sealing discs	47
Spannzangen / Gewindebohrzangen Collets / Tapping collets	48–50
TOOLFIX Werkzeugmontagegerät TOOLFIX mounting equipment	51

DIN 69871

Art-Nr. 40.01. ...

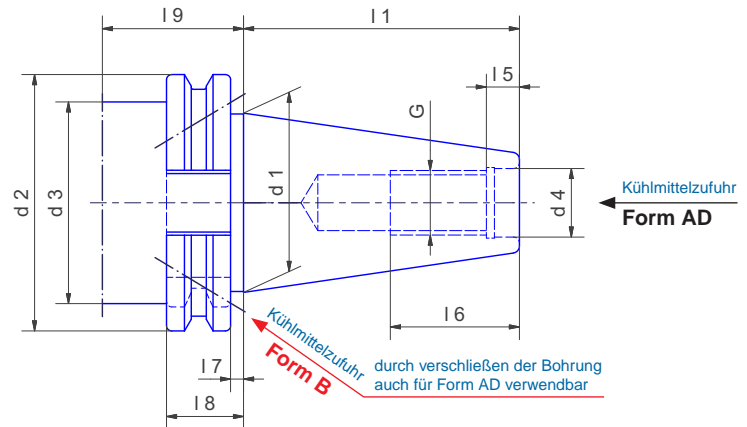
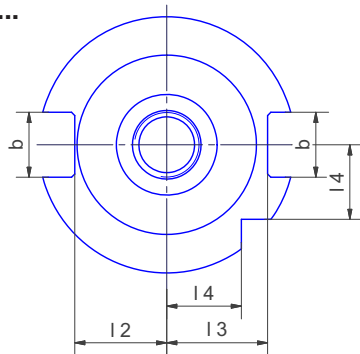

SK	d 1	d 2	d 3	d 4	G	b	l 1	l 2	l 3	l 4	l 5	l 6	l 7	l 8	l 9
25	25,40	37,00	-	8,5	M 8	12,2	39,70	12,9	12,9	-	5,5	18	-	8,0	-
30	31,75	50,00	45	13	M12	16,1	47,80	16,3	18,8	15,0	5,5	24	3,2	19,1	35
40	44,45	63,55	50	17	M16	16,1	68,40	22,7	25,0	18,5	8,2	32	3,2	19,1	35
45	57,15	82,55	63	21	M20	19,3	82,70	29,1	31,3	24,0	10,0	40	3,2	19,1	35
50	69,85	97,50	80	25	M24	25,7	101,75	35,5	37,7	30,0	11,5	47	3,2	19,1	35

MAS BT (JIS B 6339)

Art-Nr. 40.05. ...

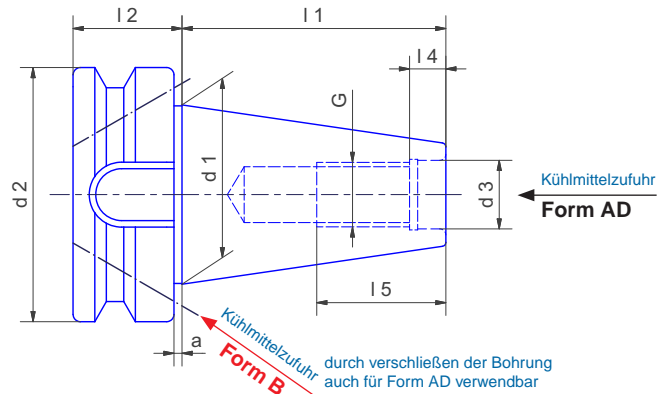
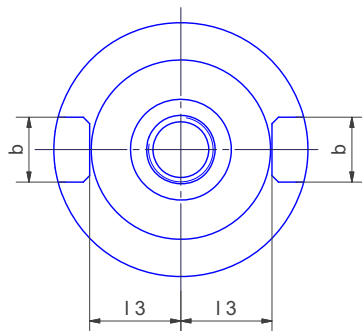

BT	d 1	d 2	d 3	G	a	b	l 1	l 2	l 3	l 4	l 5
15	19,05	27	6,5	M 6	1,5	8,1	27,0	12,5	9,7	5,0	20
20	22,23	30	8,5	M 8	1,5	8,1	25,0	12,5	11,4	6,5	18
25	25,40	35	8,5	M 8	2,0	9,7	40,0	15,1	12,9	6,5	20
30	31,75	46	12,5	M12	2,0	16,1	48,4	22,0	16,3	7,0	24
35	38,10	53	13,0	M12	2,0	14,0	56,5	22,0	19,3	7,0	27
40	44,45	63	17,0	M16	2,0	16,1	65,4	27,0	22,6	8,2	30
45	57,15	85	21,0	M20	3,0	19,3	82,8	33,0	29,1	9,0	40
50	69,85	100	25,0	M24	3,0	25,7	101,8	38,0	35,4	11,0	45

Werkstoff: Legierter Einsatzstahl mit einer Zugfestigkeit im Kern von min. 800 N/mm²

Material: Case hardened steel, tensile strength in the core min. 800 N/mm²

Ausführung: Einsatzgehärtet HRC 60 - 2 (HV 700 ± 50)
Härtetiefe 0,8 mm - 0,2
Brüniert und Präzisionsgeschliffen

Execution: Case hardened HRC 60 - 2 (HV 700 ± 50)
Depth of case 0,8 mm - 0,2
Brown-finish end precision ground

Kegelwinkel: AT3, Rundlaufgenauigkeit
Steilkegel zu Werkzeugaufnahme < 0,005

Taper angle: AT3, concentricity from the taper to the holding part < 0,005

Technische Änderungen vorbehalten

We reserve the right to make technical changes

Räumwerkzeughalter Broaching toolholder

Lieferumfang ohne Räumstempel
Delivery without broaching cutter

Räumstempel finden Sie im Zürn-Katalog Nr. 162
Broaching cutters you can find in the catalogue No. 162



MAS BT 15

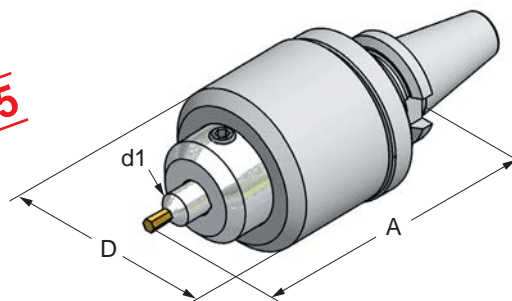

MAS BT 15

Art.-Nr.	Typ	d1	D	A
15.05.08.5000	BT15x08x78	8	40	78

Schrumpffutter ohne Kühlkanal Shrinking chucks without coolant channels

Kegelwinkel AT3, Rundlaufgenauigkeit SK zu Werkzeugaufnahme < 0,005
Taper angle AT3, Concentricity from the taper to the holding part < 0,005

G 2,5 - 30.000 U/min. oder U < 1 gmm



MAS BT 15

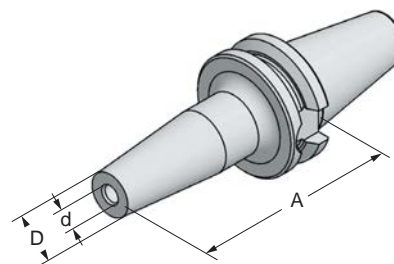

MAS BT 15

Art.-Nr.	Typ	A	d	D	Art.-Nr.	Typ	A	d	D
15.05.03.31	BT15x03Sx50-AD	50	3	10	15.05.06.31	BT15x06Sx50-AD	50	6	14
15.05.04.31	BT15x04Sx50-AD	50	4	10	15.05.08.31	BT15x08Sx50-AD	50	8	14
15.05.05.31	BT15x05Sx50-AD	50	5	14	15.05.10.31	BT15x10Sx40-AD	40	10	16

Spannzangenfutter für Spannzangen DIN 6499 (ER/ESX) Collet chucks for collets DIN 6499 (ER/ESX)

Kegelwinkel AT3, Rundlaufgenauigkeit SK zu Werkzeugaufnahme < 0,005
Taper angle AT3, Concentricity from the taper to the holding part < 0,005

G 2,5 - 30.000 U/min. oder U < 1 gmm

Spannzangen siehe Seiten 48+49
Collets see pages 48+49



MAS BT 15

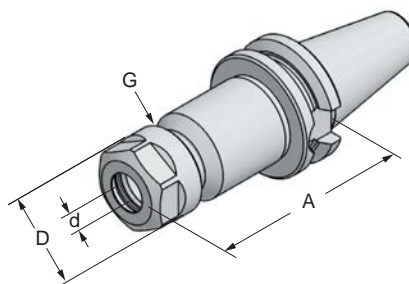

MAS BT 15

Art.-Nr.	Typ	A	d	D	G	Art.-Nr.	Typ	A	d	D	G
15.05.07.2	BT15xER11x50-AD	50	1-7	19	M14x0,75	15.05.10.2	BT15xER16x40-AD	40	1-10	28	M22x1,5
						15.05.10.22	BT15xER16x75-AD	75	1-10	28	M22x1,5



Spannzangenfutter für Spannzangen ER/ESX DIN 6499 / ISO 15488

Collet chucks for collets ER/ESX DIN 6499 / ISO 15488

Rundlaufgenauigkeit Steilkegel zu Werkzeugaufnahme < 0,005
Concentricity from the taper to the holding part < 0,005

BT-P30 G 2,5 - 25.000 U/min. oder U < 1 gmm

BT-P40 G 2,5 - 20.000 U/min. oder U < 1 gmm

Lieferumfang ohne Werkzeug und Spannzange
Delivery without tool and collet

Spannzangen siehe Seiten 48+49
Collets see pages 48+49



MAS BT-P mit Plananlage
MAS BT-P with flange contact

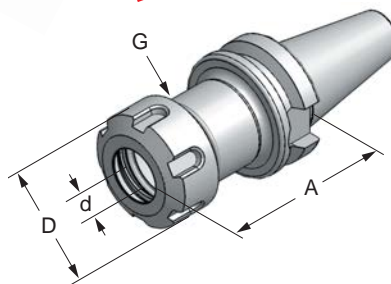

BT-P30

BT-P40

Art.-Nr.	Typ	A	d	D	G	Art.-Nr.	Typ	A	d	D	G
30.06.07.2	BT-P30xER11x 70-AD	70	1 - 7	19	M14x0,75	40.06.10.2	BT-P40xER16x 70-AD	70	1-10	28	M22x1,50
30.06.10.2	BT-P30xER16x 70-AD	70	1-10	28	M22x1,50	30.06.10.20	BT-P30xER16x 50-AD	50	1-10	28	M22x1,50
30.06.16.2	BT-P30xER25x 70-AD	70	1-16	42	M32x1,50	40.06.16.2	BT-P40xER25x 70-AD	70	1-16	42	M32x1,50
30.06.16.20	BT-P30xER25x 50-AD	50	1-16	42	M32x1,50	40.06.20.2	BT-P40xER32x 70-AD	70	2-20	50	M40x1,50
30.06.20.2	BT-P30xER32x 70-AD	70	2-20	50	M40x1,50	40.06.20.2	BT-P40xER32x 70-AD	70	2-20	50	M40x1,50
30.06.20.20	BT-P30xER32x 50-AD	50	2-20	50	M40x1,50						
30.06.07.22	BT-P30xER11x100-AD	100	1 - 7	19	M14x0,75	40.06.10.22	BT-P40xER16x100-AD	100	1-10	28	M22x1,50
30.06.10.22	BT-P30xER16x100-AD	100	1-10	28	M22x1,50	40.06.16.22	BT-P40xER25x100-AD	100	1-16	42	M32x1,50
30.06.16.22	BT-P30xER25x100-AD	100	1-16	42	M32x1,50	40.06.20.22	BT-P40xER32x100-AD	100	2-20	50	M40x1,50
30.06.20.22	BT-P30xER32x100-AD	100	2-20	50	M40x1,50						

Für Schneidwerkzeuge mit interner Kühlmittelzufuhr benötigen Sie GMGC Spannmutter und DS-Dichtscheiben
For cutting tools with internal coolant you need GMGC clamping nuts and DS-sealing discs



Spannmutter gleitgelagert DIN 6499 für Dichtscheiben
Clamping nut friction bearing DIN 6499 for sealing disc

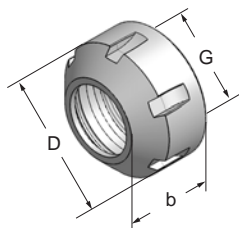

Dichtscheiben für Werkzeuge mit interner Kühlmittelzufuhr
Sealing discs for tools with internal coolant supply

Der eingelegte O-Ring gewährleistet interne Kühlmittelzufuhr durch das gespannte Werkzeug direkt zur Werkzeugschneide

The inserted O-ring seal ensures a coolant supply internally through the clamped tool directly to the cutting edge

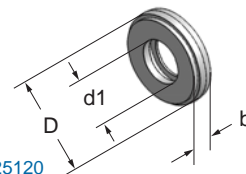

Bestellbeispiel / Example for order:
D = ø21, d1 = ø12 entspricht / equals Art.-Nr. 325120

Art.-Nr.	Typ	D	b	G	Nm max.	Art.-Nr.	Typ	D	b	d1
716124	GMGC / ER16	28	23	M 22x1,50	70	316...	DS / ER16	13,0	4	316050 - 316100
720124	GMGC / ER20	34	25	M 25x1,50	100	320...	DS / ER20	16,0	4	320050 - 320130
725124	GMGC / ER25	42	26	M 32x1,50	130	325...	DS / ER25	21,0	4	325050 - 325160
732124	GMGC / ER32	50	28	M 40x1,50	170	332...	DS / ER32	27,0	4	332050 - 332200

Kühlmitteldruck / Coolant pressure min. 5 bar - max. 100 bar

Steilkegel-Werkzeugaufnahmen BT-P ISO Taper-toolholders BT-P



Zylinderschaftaufnahmen Weldon DIN 1835 B

Holder for straight shank tools Weldon DIN 1835 B

Rundlaufgenauigkeit Steilkegel zu Werkzeugaufnahme < 0,005
Concentricity from the taper to the holding part < 0,005

BT-P30 G 2,5 - 25.000 U/min. oder U < 1 gmm

BT-P40 G 2,5 - 20.000 U/min. oder U < 1 gmm

Spannschrauben siehe Seite 46
Clamping nuts see page 46



BT-P30



MAS BT-P mit Plananlage
MAS BT-P with flange contact

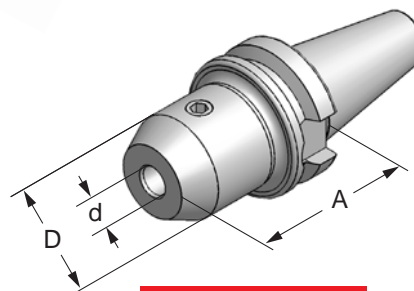

BT-P40

Art.-Nr.	Typ	A	d	D	Art.-Nr.	Typ	A	d	D
30.06.06.60	BT-P30x06x 60-AD	60	6	25					
30.06.08.60	BT-P30x08x 60-AD	60	8	28					
30.06.10.60	BT-P30x10x 60-AD	60	10	35					
30.06.12.60	BT-P30x12x 60-AD	60	12	42					
30.06.14.60	BT-P30x14x 60-AD	60	14	44					
30.06.16.60	BT-P30x16x 60-AD	60	16	48					
30.06.20.60	BT-P30x20x 60-AD	60	20	52					
30.06.06.62	BT-P30x06x100-AD	100	6	25	40.06.06.62	BT-P40x06x100-AD	100	6	25
30.06.08.62	BT-P30x08x100-AD	100	8	28	40.06.08.62	BT-P40x08x100-AD	100	8	28
30.06.10.62	BT-P30x10x100-AD	100	10	35	40.06.10.62	BT-P40x10x100-AD	100	10	35
30.06.12.62	BT-P30x12x100-AD	100	12	42	40.06.12.62	BT-P40x12x100-AD	100	12	42
30.06.16.62	BT-P30x16x100-AD	100	16	48	40.06.16.62	BT-P40x16x100-AD	100	16	48
					40.06.20.62	BT-P40x20x100-AD	100	20	52

Zylinderschaftaufnahmen Weldon DIN 1835 B - mit Kühlkanälen

Holder for straight shank tools Weldon DIN 1835 B - with coolant channels

Rundlaufgenauigkeit Steilkegel zu Werkzeugaufnahme < 0,005
Concentricity from the taper to the holding part < 0,005

BT-P30 G 2,5 - 25.000 U/min. oder U < 1 gmm

BT-P40 G 2,5 - 20.000 U/min. oder U < 1 gmm

Spannschrauben siehe Seite 46
Clamping nuts see page 46



BT-P30



MAS BT-P mit Plananlage
MAS BT-P with flange contact

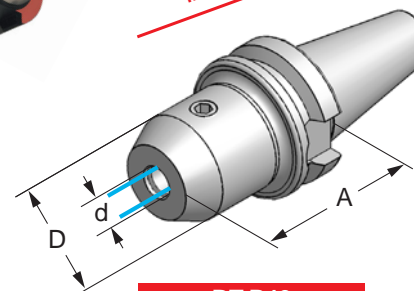

BT-P40

Art.-Nr.	Typ	A	d	D	Art.-Nr.	Typ	A	d	D
30.06.06.66	BT-P30x06x 60-AD+C	60	06	25	40.06.06.66	BT-P40x06x 65-AD+C	65	06	25
30.06.08.66	BT-P30x08x 60-AD+C	60	08	28	40.06.08.66	BT-P40x08x 65-AD+C	65	08	28
30.06.10.66	BT-P30x10x 60-AD+C	60	10	35	40.06.10.66	BT-P40x10x 65-AD+C	65	10	35
30.06.12.66	BT-P30x12x 60-AD+C	60	12	42	40.06.12.66	BT-P40x12x 65-AD+C	65	12	42
30.06.16.66	BT-P30x16x 60-AD+C	60	16	48	40.06.16.66	BT-P40x16x 65-AD+C	65	16	48
30.06.20.66	BT-P30x20x 60-AD+C	60	20	52	40.06.20.66	BT-P40x20x 65-AD+C	65	20	52
30.06.25.66	BT-P30x25x 75-AD+C	75	25	49					
30.06.06.662	BT-P30x06x100-AD+C	100	6	25	40.06.20.662	BT-P40x20x100-AD+C	100	20	52
30.06.08.662	BT-P30x08x100-AD+C	100	8	28	40.06.25.662	BT-P40x25x100-AD+C	100	25	63
					40.06.32.662	BT-P40x32x100-AD+C	100	32	72



Steilkegel-Werkzeugaufnahmen BT-P ISO Taper-toolholders BT-P



Schrumpffutter ohne Kühlkanäle Shrinking chucks without coolant channels

Rundlaufgenauigkeit Steilkegel zu Werkzeugaufnahme < 0,005
Concentricity from the taper to the holding part < 0,005

BT-P30 G 2,5 - 25.000 U/min. oder U < 1 gmm
BT-P40 G 2,5 - 20.000 U/min. oder U < 1 gmm



MAS BT-P mit Plananlage
MAS BT-P with flange contact



BT-P30

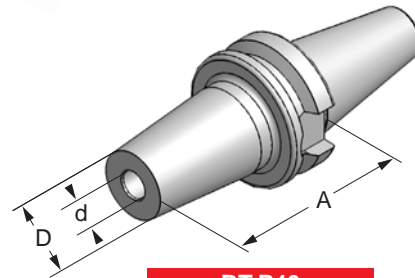

BT-P40

Art.-Nr.	Typ	A	d	D	Art.-Nr.	Typ	A	d	D
30.06.03.31	BT-P30x03Sx70-AD	70	3	10					
30.06.04.31	BT-P30x04Sx70-AD	70	4	11					
30.06.05.31	BT-P30x05Sx70-AD	70	5	14					
30.06.06.31	BT-P30x06Sx70-AD	70	6	21	40.06.06.31	BT-P40x06Sx90-AD	90	6	21
30.06.08.31	BT-P30x08Sx70-AD	70	8	21	40.06.08.31	BT-P40x08Sx90-AD	90	8	21
30.06.10.31	BT-P30x10Sx70-AD	70	10	24	40.06.10.31	BT-P40x10Sx90-AD	90	10	24
30.06.12.31	BT-P30x12Sx70-AD	70	12	24	40.06.12.31	BT-P40x12Sx90-AD	90	12	24
30.06.14.31	BT-P30x14Sx70-AD	70	14	27	40.06.14.31	BT-P40x14Sx90-AD	90	14	27
30.06.16.31	BT-P30x16Sx70-AD	70	16	27	40.06.16.31	BT-P40x16Sx90-AD	90	16	27
30.06.20.31	BT-P30x20Sx70-AD	70	20	33	40.06.20.31	BT-P40x20Sx90-AD	90	20	33

Schrumpffutter POWER-FLASH high speed Shrinking chucks POWER-FLASH high speed

Rundlaufgenauigkeit Steilkegel zu Werkzeugaufnahme < 0,005
Concentricity from the taper to the holding part < 0,005

Optimale Kühlmittelzufuhr über Kühlkanäle in der Bohrung
Best possible coolant supply through coolant channels in the boring

BT-P30 G 2,5 - 25.000 U/min. oder U < 1 gmm

Lieferumfang ohne Werkzeug
Delivery without tool



MAS BT-P mit Plananlage
MAS BT-P with flange contact



BT-P30

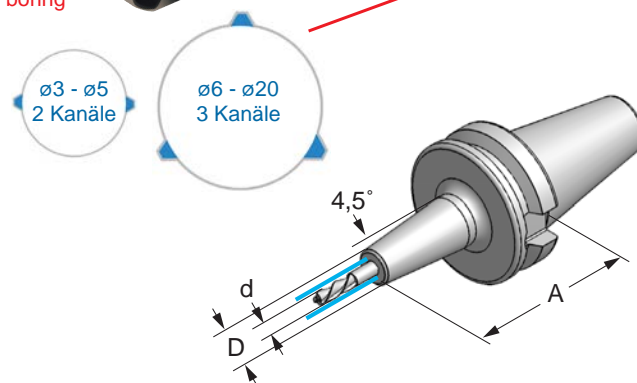

Art.-Nr.	Typ	A	d	D					
30.06.03.37	BT-P30x03SCx70-AD	70	3	10					
30.06.04.37	BT-P30x04SCx70-AD	70	4	11					
30.06.05.37	BT-P30x05SCx70-AD	70	5	14					
30.06.06.37	BT-P30x06SCx70-AD	70	6	21					
30.06.08.37	BT-P30x08SCx70-AD	70	8	21					
30.06.10.37	BT-P30x10SCx70-AD	70	10	24					
30.06.12.37	BT-P30x12SCx70-AD	70	12	24					
30.06.16.37	BT-P30x16SCx70-AD	70	16	27					
30.06.20.37	BT-P30x20SCx70-AD	70	20	33					



Messerkopfaufnahmen DIN 6357

Shell mill adaptors for facing cutters DIN 6357

Rundlaufgenauigkeit Steilkegel zu Werkzeugaufnahme < 0,005
 Concentricity from the taper to the holding part < 0,005

BT-P30 G 2,5 - 25.000 U/min. oder U < 1 gmm

BT-P40 G 2,5 - 20.000 U/min. oder U < 1 gmm



MAS BT-P mit Plananlage
 MAS BT-P with flange contact

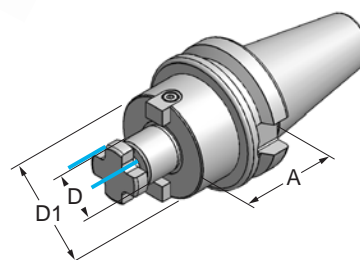

BT-P30

BT-P40

Art.-Nr.	Typ	A	D	D1	Art.-Nr.	Typ	A	D	D1
30.06.16.9	BT-P30x16x40-AD+C	40	16	39	40.06.16.9	BT-P40x16x60-AD+C	60	16	39
30.06.22.9	BT-P30x22x40-AD+C	40	22	48	40.06.22.9	BT-P40x22x60-AD+C	60	22	49
30.06.27.9	BT-P30x27x40-AD+C	40	27	48	40.06.27.9	BT-P40x27x60-AD+C	60	27	60
					40.06.32.9	BT-P40x32x60-AD+C	60	32	68
					40.06.16.92	BT-P40x16x100-AD+C	100	16	39
					40.06.22.92	BT-P40x22x100-AD+C	100	22	49
					40.06.27.92	BT-P40x27x100-AD+C	100	27	60
					40.06.32.92	BT-P40x32x100-AD+C	100	32	68

Aufnahmen für Einschraubfräser

Adaptors for end mills with thread shank

Rundlaufgenauigkeit Steilkegel zu Werkzeugaufnahme < 0,005
 Concentricity from the taper to the holding part < 0,005

BT-P30 G 2,5 - 25.000 U/min. oder U < 1 gmm

Lieferumfang ohne Fräser
 Delivery without tool



MAS BT-P mit Plananlage
 MAS BT-P with flange contact

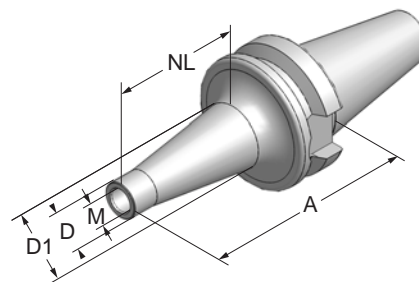

BT-P30

Art.-Nr.	Typ	M	A	NL	D	D1
30.06.08.025	BT-P30xM 8x25-AD	8	50	25	13	15
30.06.08.050	BT-P30xM 8x50-AD	8	75	50	13	23
30.06.10.025	BT-P30xM10x25-AD	10	50	25	18	20
30.06.10.050	BT-P30xM10x50-AD	10	75	50	18	25
30.06.12.025	BT-P30xM12x25-AD	12	50	25	21	24
30.06.12.050	BT-P30xM12x50-AD	12	75	50	21	24
30.06.16.025	BT-P30xM16x25-AD	16	50	25	29	34

Rohling
Blank

Sondergrößen auf Anfrage!
Special size on inquiry!



BT-P30



MAS BT-P mit Plananlage
MAS BT-P with flange contact

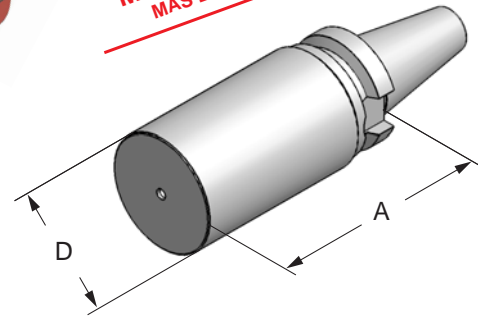

BT-P40

Art.-Nr.	Typ	A	D	Art.-Nr.	Typ	A	D
30.06.100.046	BT-P30xø46x100	100	46	40.06.200.064	BT-P40xø64x200	200	64
30.06.150.046	BT-P30xø46x150	150	46				

Anzugsbolzen MAS BT30x45°/60°
Retention knobs MAS BT30x45°/60°

Anzugsbolzen MAS BT40 siehe Seite 43
Retention knobs MAS BT40 see page 43

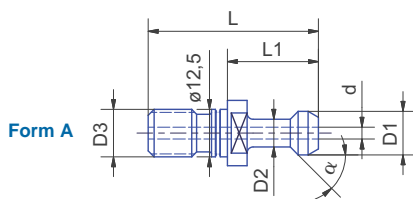

Form A

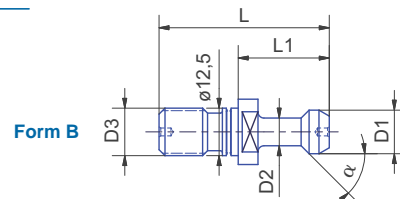

Form B

Anzugsbolzen

Art.-Nr.	Typ	D1	D2	D3	L	L1	α	d	Form
30.12.4	BT30x45°	11,0	7,0	M12	43	23	45°	-	B
30.12.4-C	BT30x45° iK	11,0	7,0	M12	43	23	45°	ø2,5	A
30.12.41	BT30x60°	11,0	7,0	M12	43	23	60°	-	B
30.12.41-C	BT30x60° iK	11,0	7,0	M12	43	23	60°	ø2,5	A
30.12.43-C	BT30x45° iK Fanuc	11,0	8,0	M12	43	23	45°	ø4	A
30.12.44-C	BT30x60° iK Brother	11,0	7,5	M12	43	23	60°	ø4	A

Anzugsbolzen SK30x45° für Fanuc Maschinen
Retention knob SK30x45° for Fanuc machines

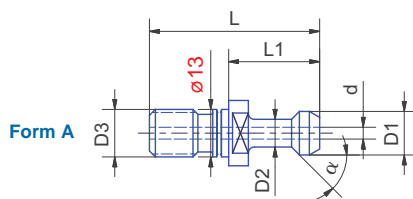

Form A



Anzugsbolzen

Art.-Nr.	Typ	D1	D2	D3	L	L1	α	d	Form
30.12.1-F	SK30x45° iK Fanuc	11,0	8,0	M12	43,6	23,6	45°	ø4	A

Spannzangenfutter MAS BT15-30 - ETS16

Collet chucks MAS BT15-30 - ETS16

G 2,5 - 25.000 U/min. oder U < 1 gmm

Lieferumfang ohne Werkzeug und Spannzange
Delivery without tool and collet

Spannzangen siehe Seiten 48+49
Collets see pages 48+49

incl. Spannmutter ETS16



MAS BT

Art.-Nr.	Typ	SK	A	D
15.05.10.20E	BT15xETS16x40-AD	15	40	27
20.05.10.20E	BT20xETS16x40-AD	20	40	30
25.05.10.20E	BT25xETS16x45-AD	25	45	35
30.05.10.20E	BT30xETS16x60-AD	30	60	46
30.05.10.20EC	BT30xETS16Cx65-AD	30	65	46
30.05.10.22E	BT30xETS16x100-AD	30	100	46
30.05.10.22EC	BT30xETS16Cx105-AD	30	105	46

Spannzangenfutter MAS BT15-30 DIN 6499 - ER16

Collet chucks MAS BT15-30 DIN 6499 - ER16

G 2,5 - 25.000 U/min. oder U < 1 gmm

Lieferumfang ohne Werkzeug und Spannzange
Delivery without tool and collet

Spannzangen siehe Seiten 48+49
Collets see pages 48+49

incl. Spannmutter ER16



MAS BT

Art.-Nr.	Typ	SK	A	D
15.05.10.20M	BT15xER16x40-AD	15	40	27
20.05.10.20M	BT20xER16x40-AD	20	40	30
25.05.10.20M	BT25xER16x45-AD	25	45	35
30.05.10.20M	BT30xER16x60-AD	30	60	46
30.05.10.20MC	BT30xER16Cx65-AD	30	65	46
30.05.10.22M	BT30xER16x100-AD	30	100	46
30.05.10.22MC	BT30xER16Cx105-AD	30	105	46

Spannmuttern - ETS16 + ETS16C

Collets - ETS16 + ETS16C

Lieferumfang ohne Werkzeug und Spannzange
Delivery without tool and collet

716120-2ETS
Spannmutter ETS16



716124-2ETS
Spannmutter ETS16C
abgedichtet
Nur Nennmaßspannung



916163
Spannschlüssel
ETS16 + ETS16C

Art.-Nr.	Typ
716120-2ETS	Spannmutter ETS16
716124-2ETS	Spannmutter ETS16C
916163	Spannschlüssel ETS16 + ETS16C

Spannmuttern - ER16 + ER16C

Collets - ER16 + ER16C

Lieferumfang ohne Werkzeug und Spannzange
Delivery without tool and collet

716120-2
Spannmutter ER16



716124-2
Spannmutter ER16C
abgedichtet



916162
Spannschlüssel
ER16 + ER16C

Art.-Nr.	Typ
716120-2	Spannmutter ER16
716124-2	Spannmutter ER16C
916162	Spannschlüssel ER16 + ER16C

Dichtscheiben - ER16C + ETS16

Sealing discs - ER16C + ETS16C

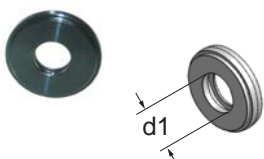

Art.-Nr.	d1
316030	ø3 - 2
316040	ø4 - 3
316050	ø5 - 4
316060	ø6 - 5
316070	ø7 - 6
316080	ø8 - 7
316090	ø9 - 8
316100	ø10-9

Dichtscheiben - 3 Kühlkanäle für externe Kühlmittelzufuhr

Sealing discs - 3 coolant channels for external coolant

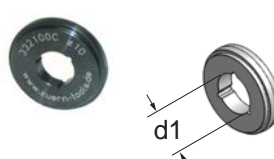

Art.-Nr.	d1
316040C	ø4 - ø3
316060C	ø6 - ø5
316080C	ø8 - ø7

Spannzangenfutter für Spannzangen DIN 6499 (ER/ESX) + ETS16
Collet chucks for collets DIN 6499 (ER/ESX) + ETS16

Rundlaufgenauigkeit Steilkegel zu Werkzeugaufnahme < 0,005
Concentricity from the taper to the holding part < 0.005

µm-tool



Justierbar mit 4 Verstellschrauben
Adjustable with 4 screws



0-2 µm



10-30 µm

Standard-Werkzeughalter
Standard-toolholder



Funktion:

Werkzeug-Rundlauffehler feststellen und dann Spannring mit Schraube in Position bringen. Schraube spannen bis Rundlauffehler 0 - dann die restlichen Schrauben fest anlegen.

Function:

The run-out error of the tool must be determined and the clamping ring with screw must be brought in position. Screw must be tightened until run-out error is 0 - after that the remaining screws can be tightened.

Spannzangenfutter MAS BT30 radial feinverstellbar

Collet chucks MAS BT30 radially adjustable



DIN 6499 - ER/ESX11 (ø1-7)

Lieferumfang ohne Spannzange
Delivery without collet
Spannzangen siehe Seiten 48+49
Collets see pages 48+49



30.05.07.28
(incl. Spannmutter ER11)

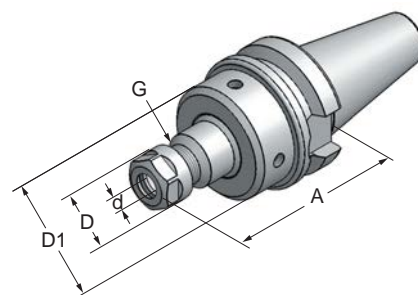

MAS BT 30

Art.-Nr.	Typ	A	d	D	D1	G
30.05.07.28	BT30xER11x70-AD incl. Spannmutter ER11	70	1- 7	19	40	M14x0,75

DIN 6499 - ER/ESX16 (ø1-10)

Lieferumfang ohne Spannzange
Delivery without collet
Spannzangen siehe Seiten 48+49
Collets see pages 48+49



optional

716124-2 Spannmutter ER16C
für Dichtscheiben
(Dichtscheiben separat bestellen)

30.05.10.28
(incl. Spannmutter ER16)

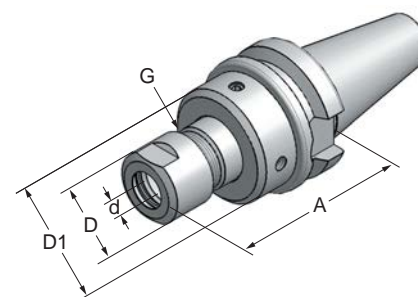

MAS BT 30

Art.-Nr.	Typ	A	d	D	D1	G
30.05.10.28	BT30xER16x70-AD incl. Spannmutter ER16	70	1-10	25	40	M20x1
716124-2	Spannmutter ER16C für Dichtscheiben		1-10	25		M20x1

ETS16 (ø1-10)

Lieferumfang ohne Spannzange
Delivery without collet
Spannzangen siehe Seiten 48+49
Collets see pages 48+49



optional

716124-2ETS Spannmutter ETS16C
für Dichtscheiben
(Dichtscheiben separat bestellen)

30.05.10.282
(incl. Spannmutter ETS16)

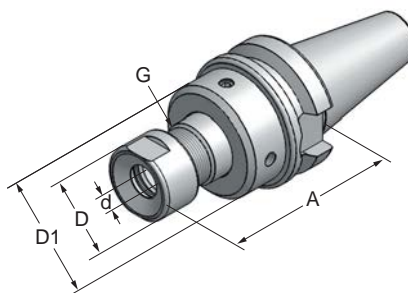

MAS BT 30

Art.-Nr.	Typ	A	d	D	D1	G
30.05.10.282	BT30xETS16x70-AD incl. Spannmutter ETS16	70	1-10	27	40	M20x1
716124-2ETS	Spannmutter ETS16C für Dichtscheiben		1-10	27		M20x1

Spannschlüssel



916162
SW 22



916163
SW 24

Art.-Nr.	Typ
916162	Spannschlüssel SW 22 für ER16 + ER 16C
916163	Spannschlüssel SW 24 für ETS16 + ETS 16C

Dichtscheiben für ER16C / ETS16C



Art.-Nr.	d1
316030	ø3 - 2
316040	ø4 - 3
316050	ø5 - 4
316060	ø6 - 5
316070	ø7 - 6
316080	ø8 - 7
316090	ø9 - 8
316100	ø10-9

Spannzangenfutter DIN 6391 ohne Mitnehmernut für Spannzangen DIN 6388 / ISO 10897

Collet chucks DIN 6391 without groove for collets ER/ESX DIN 6388 / ISO 10897

Kegelwinkel AT3, Rundlaufgenauigkeit SK zu Werkzeugaufnahme < 0,005
Taper angle AT3, Concentricity from the taper to the holding part < 0,005

SK30 G 2,5 - 25.000 U/min. oder U < 1 gmm
SK40 G 2,5 - 20.000 U/min. oder U < 1 gmm

Spannzangen auf Anfrage
Collets on inquiry

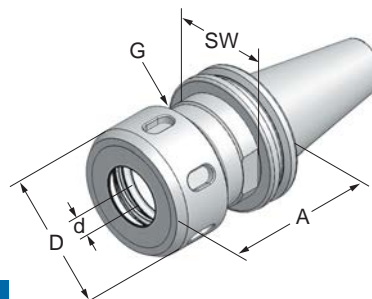

DIN 69871

Art.-Nr.	Typ	Spannzange / Collet	d	D	A	SW	G
30.01.25.01	SK30xOZ25x70-AD	444E / 462E	2 - 25	60	70	36	M48x2,0
40.01.16.01	SK40xOZ16x70-AD	410E / 415E	2 - 16	43	70	36	M33x1,5
40.01.25.01	SK40xOZ25x70-AD	444E / 462E	2 - 25	60	70	46	M48x2,0

Spannzangenfutter ohne Mitnehmernut für Spannzangen ER/ESX DIN 6499 / ISO 15488

Collet chucks without groove for collets ER/ESX DIN 6499 / ISO 15488

Kegelwinkel AT3, Rundlaufgenauigkeit SK zu Werkzeugaufnahme < 0,005
Taper angle AT3, Concentricity from the taper to the holding part < 0,005

SK30 G 2,5 - 25.000 U/min. oder U < 1 gmm
SK40 G 2,5 - 20.000 U/min. oder U < 1 gmm

Spannzangen siehe Seiten 48+49
Collets see pages 48+49

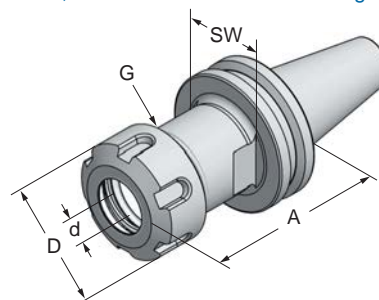

DIN 69871

Art.-Nr.	Typ	Spannzange / Collet	d	D	A	SW	G
30.01.10.02	SK30xER16x 70-AD	ER16 / 426E	1 - 10	28	70	24	M22x1,5
30.01.10.022	SK30xER16x100-AD	ER16 / 426E	1 - 10	28	100	24	M22x1,5
30.01.16.02	SK30xER25x 70-AD	ER25 / 430E	2 - 16	42	70	27	M32x1,5
30.01.16.022	SK30xER25x100-AD	ER25 / 430E	2 - 16	42	100	27	M32x1,5
30.01.20.02	SK30xER32x 70-AD	ER32 / 470E	3 - 20	50	70	36	M40x1,5
30.01.20.022	SK30xER32x100-AD	ER32 / 470E	3 - 20	50	100	36	M40x1,5
30.01.26.02	SK30xER40x 70-AD	ER40 / 472E	4 - 26	63	70	41	M50x1,5
40.01.16.02	SK40xER25x 70-AD	ER25 / 430E	2 - 16	42	70	36	M32x1,5
40.01.20.02	SK40xER32x 70-AD	ER32 / 470E	3 - 20	50	70	36	M40x1,5
40.01.26.02	SK40xER40x 70-AD	ER40 / 472E	4 - 26	63	70	46	M50x1,5

Pendelhalter, achsparallel ausgleichend einstellbar, mit auswechselbaren Einsätzen

Floating holders with compensation adjustment parallel to the axis, with interchangeable cartridges

Lieferumfang ohne Einsatz
Delivery without insert

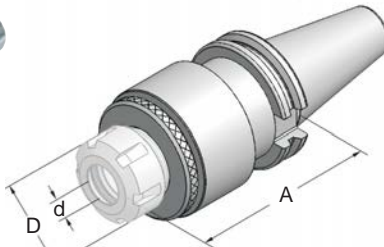

*Der Einsatz muss separat bestellt werden!
The insert has to be ordered separately!*



Abb. mit Einsatz 101101 ER25
Picture with insert 101101 ER25

DIN 69871

MAS BT

Art.-Nr.	Typ	A	d	D	Art.-Nr.	Typ	A	d	D
40.01.70.350	SK40-AD+B	105	2-16	42	40.05.70.350	BT40-AD+B	105	2-16	42
50.01.70.350	SK50-AD+B	105	2-16	42	50.05.70.350	BT50-AD+B	105	2-16	42

Einsätze für Pendelhalter

Inserts for floating holder



Spannzangenhalter

Zylinderschaft

MK 2

Art.-Nr.	Typ	Art.-Nr.	Typ	Art.-Nr.	Typ
101101	Einsatz/Insert ER 25/430E*	105101	Einsatz/Insert B ø16	109101	Einsatz/Insert C-MK2
102101	Einsatz/Insert DA180/419E*	106101	Einsatz/Insert B ø18		
* incl. Spannmutter/Clamping nut		107101	Einsatz/Insert B ø20		
		108101	Einsatz/Insert B ø25		

Spannzangenfutter für Spannzangen ER/ESX DIN 6499 / ISO 15488

Collet chucks for collets ER/ESX DIN 6499 / ISO 15488

Kegelwinkel AT3, Rundlaufgenauigkeit SK zu Werkzeugaufnahme < 0,005
Taper angle AT3, Concentricity from the taper to the holding part < 0,005

SK30/BT30 G 2,5 - 25.000 U/min. oder U < 1 gmm
SK40/BT40 G 2,5 - 20.000 U/min. oder U < 1 gmm
SK50/BT50 G 2,5 - 15.000 U/min. oder U < 1 gmm

Spannzangen siehe Seiten 48+49
Collets see pages 48+49

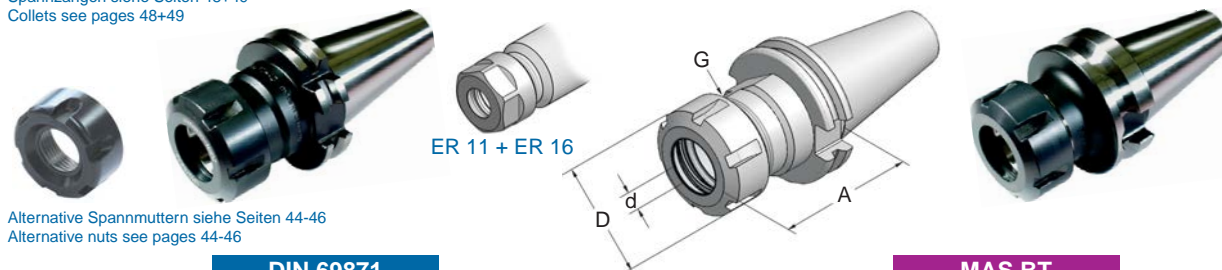

DIN 69871

MAS BT

Art.-Nr.	Typ	A	d	D	G	Art.-Nr.	Typ	A	d	D	G
30.01.07.2	SK30xER11x 70-AD	70	1- 7	19	M14x0,75	30.05.07.2	BT30xER11x 70-AD	70	1- 7	19	M14x0,75
30.01.10.2	SK30xER16x 70-AD	70	1-10	28	M22x1,50	30.05.10.2	BT30xER16x 70-AD	70	1-10	28	M22x1,50
30.01.10.20	SK30xER16x 45-AD	45	1-10	28	M22x1,50	30.05.10.2-50	BT30xER16x 50-AD	50	1-10	28	M22x1,50
30.01.16.2	SK30xER25x 70-AD	70	1-16	42	M32x1,50	30.05.13.2	BT30xER20x 70-AD	70	1-13	35	M25x1,50
30.01.20.2	SK30xER32x 70-AD	70	2-20	50	M40x1,50	30.05.16.2	BT30xER25x 70-AD	70	1-16	42	M32x1,50
30.01.26.2	SK30xER40x 70-AD	70	3-30	63	M50x1,50	30.05.16.2-55	BT30xER25x 55-AD	55	1-16	42	M32x1,50
						30.05.20.2	BT30xER32x 70-AD	70	2-20	50	M40x1,50
						30.05.20.2-50	BT30xER32x 50-AD	50	2-20	50	M40x1,50
						30.05.26.2	BT30xER40x 70-AD	70	3-30	63	M50x1,50
30.01.10.22	SK30xER16x100-AD	100	1-10	28	M22x1,50	30.05.07.22	BT30xER11x100-AD	100	1- 7	19	M14x0,75
30.01.16.22	SK30xER25x100-AD	100	1-16	42	M32x1,50	30.05.10.22	BT30xER16x100-AD	100	1-10	28	M22x1,50
30.01.20.22	SK30xER32x100-AD	100	2-20	63	M40x1,50	30.05.13.22	BT30xER20x100-AD	100	1-13	35	M25x1,50
						30.05.16.22	BT30xER25x100-AD	100	1-16	42	M32x1,50
						30.05.20.22	BT30xER32x100-AD	100	2-20	50	M40x1,50
40.01.07.2	SK40xER11x 70-AD+B	70	1- 7	19	M14x0,75	40.05.10.2	BT40xER16x 70-AD	70	1-10	28	M22x1,50
40.01.10.2	SK40xER16x 70-AD+B	70	1-10	28	M22x1,50	40.05.13.21	BT40xER20x 70-AD+B	70	1-13	35	M25x1,50
40.01.13.2	SK40xER20x 70-AD+B	70	1-13	35	M25x1,50	40.05.16.2	BT40xER25x 70-AD	70	1-16	42	M32x1,50
40.01.16.2	SK40xER25x 70-AD+B	70	1-16	42	M32x1,50	40.05.20.2	BT40xER32x 70-AD	70	2-20	50	M40x1,50
40.01.20.2	SK40xER32x 70-AD+B	70	2-20	50	M40x1,50	40.05.20.21	BT40xER32x 70-AD+B	70	2-20	50	M40x1,50
40.01.26.2	SK40xER40x 70-AD+B	70	3-30	63	M50x1,50	40.05.26.2	BT40xER40x 70-AD	70	3-30	50	M50x1,50
40.01.34.2	SK40xER50x 85-AD+B	85	6-34	78	M64x2,00	40.05.26.21	BT40xER40x 70-AD+B	70	3-30	63	M50x1,50
40.01.07.22	SK40xER11x100-AD+B	100	1- 7	19	M14x0,75	40.05.07.22	BT40xER11x100-AD+B	100	1- 7	19	M14x0,75
40.01.10.22	SK40xER16x100-AD+B	100	1-10	28	M22x1,50	40.05.10.22	BT40xER16x100-AD+B	100	1-10	28	M22x1,50
40.01.13.22	SK40xER20x100-AD+B	100	1-13	35	M25x1,50	40.05.13.22	BT40xER20x100-AD+B	100	1-13	35	M25x1,50
40.01.16.22	SK40xER25x100-AD+B	100	1-16	42	M32x1,50	40.05.16.22	BT40xER25x100-AD+B	100	1-16	42	M32x1,50
40.01.20.22	SK40xER32x100-AD+B	100	2-20	50	M40x1,50	40.05.20.22	BT40xER32x100-AD+B	100	2-20	50	M40x1,50
40.01.26.22	SK40xER40x100-AD+B	100	3-30	63	M50x1,50	40.05.26.22	BT40xER40x100-AD+B	100	3-30	63	M50x1,50
40.01.10.23	SK40xER16x160-AD+B	160	1-10	28	M22x1,50	40.05.10.23	BT40xER16x160-AD+B	160	1-10	28	M22x1,50
40.01.16.23	SK40xER25x160-AD+B	160	1-16	42	M32x1,50	40.05.16.23	BT40xER25x160-AD+B	160	1-16	42	M32x1,50
40.01.20.23	SK40xER32x160-AD+B	160	2-20	50	M40x1,50	40.05.20.23	BT40xER32x160-AD+B	160	2-20	50	M40x1,50
40.01.26.23	SK40xER40x160-AD+B	160	3-30	63	M50x1,50	40.05.26.23	BT40xER40x160-AD+B	160	3-30	63	M50x1,50
50.01.10.2	SK50xER16x100-AD+B	100	1-10	28	M22x1,50	50.05.10.2	BT50xER16x100-AD+B	100	1-10	28	M22x1,50
50.01.16.2	SK50xER25x100-AD+B	100	1-16	42	M32x1,50	50.05.16.2	BT50xER25x100-AD+B	100	1-16	42	M32x1,50
50.01.20.2	SK50xER32x100-AD+B	100	2-20	50	M40x1,50	50.05.20.2	BT50xER32x100-AD+B	100	2-20	50	M40x1,50
50.01.26.2	SK50xER40x100-AD+B	100	3-30	63	M50x1,50	50.05.26.2	BT50xER40x100-AD+B	100	3-30	63	M50x1,50
50.01.34.2	SK50xER50x100-AD+B	100	6-34	78	M64x2,00	50.05.34.2	BT50xER50x100-AD+B	100	6-34	78	M64x2,00
50.01.10.23	SK50xER16x160-AD+B	160	1-10	28	M22x1,50	50.05.10.23	BT50xER16x160-AD+B	160	1-10	28	M22x1,50
50.01.16.23	SK50xER25x160-AD+B	160	1-16	42	M32x1,50	50.05.16.23	BT50xER25x160-AD+B	160	1-16	42	M32x1,50
50.01.20.23	SK50xER32x160-AD+B	160	2-20	50	M40x1,50	50.05.20.23	BT50xER32x160-AD+B	160	2-20	50	M40x1,50
50.01.26.23	SK50xER40x160-AD+B	160	3-30	63	M50x1,50	50.05.26.23	BT50xER40x160-AD+B	160	3-30	63	M50x1,50

Spannzangenfutter DIN 6391 für Spannzangen DIN 6388 / ISO 10897

Collet chucks DIN 6391 for collets DIN 6388 / ISO 10897

Kegelwinkel AT3, Rundlaufgenauigkeit SK zu Werkzeugaufnahme < 0,005

Taper angle AT3, Concentricity from the taper to the holding part < 0,005

Spannzangen auf Anfrage

Collets on inquiry

SK30/BT30 G 2,5 - 25.000 U/min. oder U < 1 gmm

SK40/BT40 G 2,5 - 20.000 U/min. oder U < 1 gmm

SK50/BT50 G 2,5 - 15.000 U/min. oder U < 1 gmm

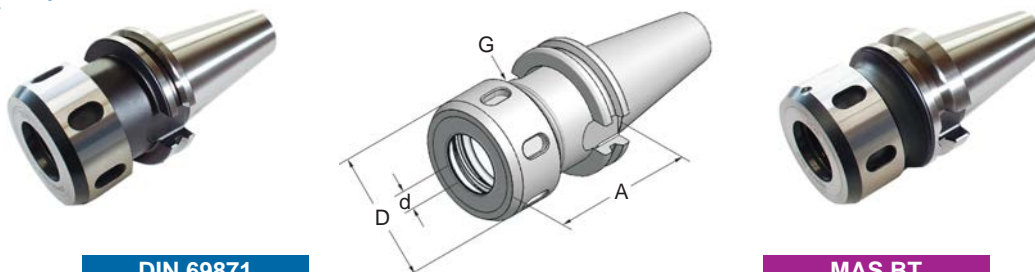

DIN 69871

MAS BT

Art.-Nr.	Typ	A	d	D	G	Art.-Nr.	Typ	A	d	D	G
						30.05.16.1	BT30xOZ16x 70-AD	70	1-16	43	M33x1,5
40.01.16.10	SK40xOZ16x 70-AD+B	70	1-16	43	M33x1,5	40.05.16.1	BT40xOZ16x 70-AD	70	1-16	43	M33x1,5
40.01.16.12	SK40xOZ16x100-AD+B	100	1-16	43	M33x1,5						
40.01.25.10	SK40xOZ25x 70-AD+B	70	2-25	60	M48x2,0	40.05.25.1	BT40xOZ25x 70-AD	70	2-25	60	M48x2,0
40.01.25.12	SK40xOZ25x100-AD+B	100	2-25	60	M48x2,0						
40.01.32.10	SK40xOZ32x 90-AD+B	90	4-32	72	M60x2,5	40.05.32.1	BT40xOZ32x 80-AD	80	4-32	72	M60x2,5
50.01.25.10	SK50xOZ25x100-AD+B	100	2-25	60	M48x2,0	50.05.25.1	BT50xOZ25x100-AD+B	100	2-25	60	M48x2,0
50.01.32.10	SK50xOZ32x100-AD+B	100	4-32	72	M60x2,5	50.05.32.1	BT50xOZ32x100-AD+B	100	4-32	72	M60x2,5

Kombi-Aufsteckfräsdorne DIN 6358

Universal arbors DIN 6358

Kegelwinkel AT3, Rundlaufgenauigkeit SK zu Werkzeugaufnahme < 0,005

Taper angle AT3, Concentricity from the taper to the holding part < 0,005

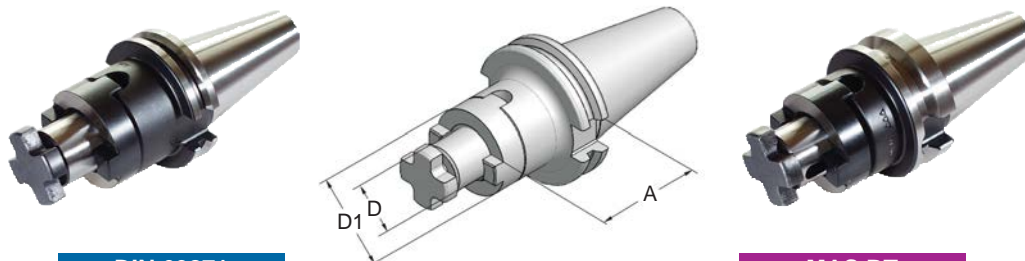

DIN 69871

MAS BT

Art.-Nr.	Typ	A	D	D1	Art.-Nr.	Typ	A	D	D1
30.01.16.4	SK30x16x 50-AD	50	16	32	30.05.16.4	BT30x16x 50-AD	50	16	32
30.01.22.4	SK30x22x 50-AD	50	22	40	30.05.22.4	BT30x22x 50-AD	50	22	40
30.01.27.4	SK30x27x 52-AD	52	27	48	30.05.27.4	BT30x27x 50-AD	50	27	48
40.01.16.4	SK40x16x 55-AD	55	16	32	40.05.16.4	BT40x16x 55-AD	55	16	32
40.01.22.4	SK40x22x 55-AD	55	22	40	40.05.22.4	BT40x22x 55-AD	55	22	40
40.01.27.4	SK40x27x 55-AD	55	27	48	40.05.27.4	BT40x27x 55-AD	55	27	48
40.01.32.4	SK40x32x 60-AD	60	32	58	40.05.32.4	BT40x32x 60-AD	60	32	58
40.01.40.4	SK40x40x 60-AD	60	40	70	40.05.40.4	BT40x40x 60-AD	60	40	70
40.01.16.42	SK40x16x100-AD	100	16	32	40.05.16.42	BT40x16x100-AD	100	16	32
40.01.22.42	SK40x22x100-AD	100	22	40	40.05.22.42	BT40x22x100-AD	100	22	40
40.01.27.42	SK40x27x100-AD	100	27	48	40.05.27.42	BT40x27x100-AD	100	27	48
40.01.32.42	SK40x32x100-AD	100	32	58	40.05.32.42	BT40x32x100-AD	100	32	58
50.01.16.4	SK50x16x 55-AD	55	16	32	50.05.16.4	BT50x16x 70-AD	70	16	32
50.01.22.4	SK50x22x 55-AD	55	22	40	50.05.22.4	BT50x22x 70-AD	70	22	40
50.01.27.4	SK50x27x 55-AD	55	27	48	50.05.27.4	BT50x27x 70-AD	70	27	48
50.01.32.4	SK50x32x 55-AD	55	32	58	50.05.32.4	BT50x32x 70-AD	70	32	58
50.01.40.4	SK50x40x 55-AD	55	40	70	50.05.40.4	BT50x40x 70-AD	70	40	70
50.01.50.4	SK50x50x 70-AD	70	50	90	50.05.50.4	BT50x50x 90-AD	90	50	90
50.01.16.42	SK50x16x100-AD	100	16	32	50.05.16.42	BT50x16x100-AD	100	16	32
50.01.22.42	SK50x22x100-AD	100	22	40	50.05.22.42	BT50x22x100-AD	100	22	40
50.01.27.42	SK50x27x100-AD	100	27	48	50.05.27.42	BT50x27x100-AD	100	27	48
50.01.32.42	SK50x32x100-AD	100	32	58	50.05.32.42	BT50x32x100-AD	100	32	58
50.01.40.42	SK50x40x100-AD	100	40	70	50.05.40.42	BT50x40x100-AD	100	40	70

Messerkopfaufnahmen DIN 6357

Shell mill adaptors for facing cutters DIN 6357

Kegelwinkel AT3, Rundlaufgenauigkeit SK zu Werkzeugaufnahme < 0,005
Taper angle AT3, Concentricity from the taper to the holding part < 0,005

SK30/BT30 G 2,5 - 25.000 U/min. oder U < 1 gmm
SK40/BT40 G 2,5 - 20.000 U/min. oder U < 1 gmm
SK50/BT50 G 2,5 - 15.000 U/min. oder U < 1 gmm

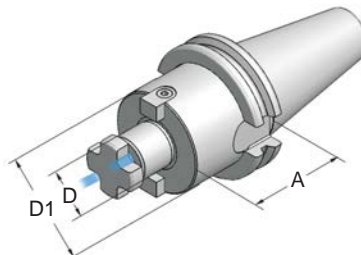

DIN 69871

MAS BT

Art.-Nr.	Typ	A	D	D1	Art.-Nr.	Typ	A	D	D1
					30.05.16.9	BT30x16x40-AD+C	40	16	39
					30.05.22.9	BT30x22x40-AD+C	40	22	48
					30.05.27.9	BT30x27x40-AD+C	40	27	48
40.01.16.9	SK40x16x50-AD+B+C	50	16	39	40.05.16.9	BT40x16x50-AD+B+C	50	16	39
40.01.22.9	SK40x22x50-AD+B+C	50	22	49	40.05.22.9	BT40x22x50-AD+B+C	50	22	49
40.01.27.9	SK40x27x50-AD+B+C	50	27	60	40.05.27.9	BT40x27x50-AD+B+C	50	27	60
40.01.32.9	SK40x32x60-AD+B+C	60	32	68	40.05.32.9	BT40x32x60-AD+B+C	60	32	68
40.01.40.9	SK40x40x60-AD+B+C	60	40	88	40.05.40.9	BT40x40x60-AD+B+C	60	40	88
50.01.22.9	SK50x22x60-AD+B+C	60	22	49	50.05.22.9	BT50x22x60-AD+B+C	60	22	49
50.01.27.9	SK50x27x60-AD+B+C	60	27	60	50.05.27.9	BT50x27x60-AD+B+C	60	27	60
50.01.32.9	SK50x32x60-AD+B+C	60	32	68	50.05.32.9	BT50x32x60-AD+B+C	60	32	68
50.01.40.9	SK50x40x70-AD+B+C	70	40	88	50.05.40.9	BT50x40x60-AD+B+C	60	40	88
50.01.60.9	SK50x60x70-AD+B+C	70	60	128	50.05.60.9	BT50x60x80-AD+B+C	80	60	128

Zylinderschaftaufnahmen Weldon DIN 1835 B

Holder for straight shank tools Weldon DIN 1835 B

Kegelwinkel AT3, Rundlaufgenauigkeit SK zu Werkzeugaufnahme < 0,005

Taper angle AT3, Concentricity from the taper to the holding part < 0,005

Spannschrauben siehe Seite 46

Clamping nuts see page 46

SK30/BT30 G 2,5 - 25.000 U/min. oder U < 1 gmm

SK40/BT40 G 2,5 - 20.000 U/min. oder U < 1 gmm

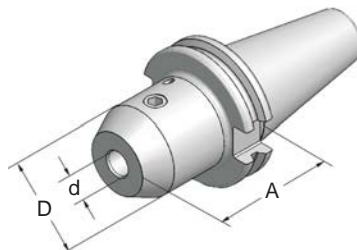

DIN 69871

MAS BT

Art.-Nr.	Typ	A	d	D	Art.-Nr.	Typ	A	d	D
30.01.06.6	SK30x06x 60-AD	60	6	25	30.05.06.60	BT30x06x 60-AD	60	6	25
30.01.08.6	SK30x08x 60-AD	60	8	28	30.05.08.60	BT30x08x 60-AD	60	8	28
30.01.10.6	SK30x10x 60-AD	60	10	35	30.05.10.60	BT30x10x 60-AD	60	10	35
30.01.12.6	SK30x12x 60-AD	60	12	42	30.05.12.60	BT30x12x 60-AD	60	12	42
30.01.14.6	SK30x14x 60-AD	60	14	44	30.05.14.60	BT30x14x 60-AD	60	14	44
30.01.16.6	SK30x16x 60-AD	60	16	48	30.05.16.60	BT30x16x 60-AD	60	16	48
30.01.18.6	SK30x18x 60-AD	60	18	50	30.05.18.60	BT30x18x 60-AD	60	18	50
30.01.20.6	SK30x20x 60-AD	60	20	50	30.05.20.60	BT30x20x 60-AD	60	20	50
30.01.25.6	SK30x25x 75-AD	75	25	50	30.05.25.60	BT30x25x 75-AD	75	25	50
					30.05.32.60	BT30x32x 85-AD	85	32	52
40.01.06.06	SK40x06x 30-AD	30	6	25	30.05.06.62	BT30x06x100-AD	100	6	25
40.01.08.06	SK40x08x 30-AD	30	8	28	30.05.08.62	BT30x08x100-AD	100	8	28
40.01.10.06	SK40x10x 30-AD	30	10	35	30.05.10.62	BT30x10x100-AD	100	10	35
40.01.12.06	SK40x12x 35-AD	35	12	42	30.05.12.62	BT30x12x100-AD	100	12	42
40.01.14.06	SK40x14x 35-AD	35	14	44	30.05.16.62	BT30x16x100-AD	100	16	48
40.01.16.06	SK40x16x 35-AD	35	16	48	30.05.20.62	BT30x20x100-AD	100	20	52
40.01.18.06	SK40x18x 35-AD	35	18	50					
40.01.20.06	SK40x20x 35-AD	35	20	50	40.05.16.06	BT40x16x 35-AD	35	16	48
40.01.25.06	SK40x25x 35-AD	35	25	50	40.05.20.06	BT40x20x 35-AD	35	20	50
40.01.32.06	SK40x32x 35-AD	35	32	50	40.05.25.06	BT40x25x 35-AD	35	25	50
40.01.06.6	SK40x06x 65-AD+B	65	6	25	40.05.06.60	BT40x06x 65-AD	65	6	25
40.01.08.6	SK40x08x 65-AD+B	65	8	28	40.05.08.60	BT40x08x 65-AD	65	8	28
40.01.10.6	SK40x10x 65-AD+B	65	10	35	40.05.10.60	BT40x10x 65-AD	65	10	35
40.01.12.6	SK40x12x 65-AD+B	65	12	42	40.05.12.60	BT40x12x 65-AD	65	12	42
40.01.14.6	SK40x14x 65-AD+B	65	14	44	40.05.14.60	BT40x14x 65-AD	65	14	44
40.01.16.6	SK40x16x 65-AD+B	65	16	48	40.05.16.60	BT40x16x 65-AD	65	16	48
40.01.18.6	SK40x18x 65-AD+B	65	18	50	40.05.18.60	BT40x18x 65-AD	65	18	50
40.01.20.6	SK40x20x 65-AD+B	65	20	50	40.05.20.60	BT40x20x 65-AD	65	20	50
40.01.25.6	SK40x25x 75-AD+B	75	25	64	40.05.25.60	BT40x25x 65-AD	65	25	64
40.01.32.6	SK40x32x 75-AD+B	75	32	72	40.05.32.60	BT40x32x 75-AD	75	32	72
40.01.40.6	SK40x40x120-AD+B	120	40	80	40.05.40.60	BT40x40x120-AD+B	120	40	80

Zylinderschaftaufnahmen Weldon DIN 1835 B

Holder for straight shank tools Weldon DIN 1835 B

Kegelwinkel AT3, Rundlaufgenauigkeit SK zu Werkzeugaufnahme < 0,005
Taper angle AT3, Concentricity from the taper to the holding part < 0,005

SK40/BT40 G 2,5 - 20.000 U/min. oder U < 1 gmm
SK50/BT50 G 2,5 - 15.000 U/min. oder U < 1 gmm

Spannschrauben siehe Seite 46
Clamping nuts see page 46

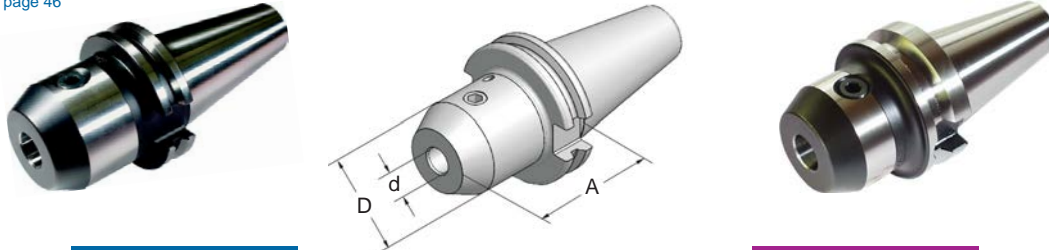

DIN 69871

MAS BT

Art.-Nr.	Typ	A	d	D	Art.-Nr.	Typ	A	d	D
40.01.06.620	SK40x06x100-AD+B	100	6	25	40.05.06.62	BT40x06x100-AD+B	100	6	25
40.01.08.620	SK40x08x100-AD+B	100	8	28	40.05.08.62	BT40x08x100-AD+B	100	8	28
40.01.10.620	SK40x10x100-AD+B	100	10	35	40.05.10.62	BT40x10x100-AD+B	100	10	35
40.01.12.620	SK40x12x100-AD+B	100	12	42	40.05.12.62	BT40x12x100-AD+B	100	12	42
40.01.14.620	SK40x14x100-AD+B	100	14	44	40.05.14.62	BT40x14x100-AD+B	100	14	44
40.01.16.620	SK40x16x100-AD+B	100	16	48	40.05.16.62	BT40x16x100-AD+B	100	16	48
40.01.18.620	SK40x18x100-AD+B	100	18	50	40.05.18.62	BT40x18x100-AD+B	100	18	50
40.01.20.620	SK40x20x100-AD+B	100	20	50	40.05.20.62	BT40x20x100-AD+B	100	20	50
40.01.25.620	SK40x25x100-AD+B	100	25	64	40.05.25.62	BT40x25x100-AD+B	100	25	64
40.01.32.620	SK40x32x100-AD+B	100	32	72	40.05.32.62	BT40x32x100-AD+B	100	32	72
40.01.06.63	SK40x06x160-AD+B	160	6	25	40.05.06.63	BT40x06x160-AD+B	160	6	25
40.01.08.63	SK40x08x160-AD+B	160	8	28	40.05.08.63	BT40x08x160-AD+B	160	8	28
40.01.10.63	SK40x10x160-AD+B	160	10	35	40.05.10.63	BT40x10x160-AD+B	160	10	35
40.01.12.63	SK40x12x160-AD+B	160	12	42	40.05.12.63	BT40x12x160-AD+B	160	12	42
40.01.16.63	SK40x16x160-AD+B	160	16	44	40.05.16.63	BT40x16x160-AD+B	160	16	44
40.01.20.63	SK40x20x160-AD+B	160	20	48	40.05.20.63	BT40x20x160-AD+B	160	20	48
50.01.06.6	SK50x06x 63-AD+B	63	6	25	50.05.06.60	BT50x06x 80-AD+B	80	6	25
50.01.08.6	SK50x08x 63-AD+B	63	8	28	50.05.08.60	BT50x08x 80-AD+B	80	8	28
50.01.10.6	SK50x10x 63-AD+B	63	10	35	50.05.10.60	BT50x10x 80-AD+B	80	10	35
50.01.12.6	SK50x12x 63-AD+B	63	12	42	50.05.12.60	BT50x12x 80-AD+B	80	12	42
50.01.14.6	SK50x14x 63-AD+B	63	14	44	50.05.14.60	BT50x14x 80-AD+B	80	14	44
50.01.16.6	SK50x16x 63-AD+B	63	16	48	50.05.16.60	BT50x16x 80-AD+B	80	16	48
50.01.18.6	SK50x18x 63-AD+B	63	18	50	50.05.18.60	BT50x18x 80-AD+B	80	18	50
50.01.20.6	SK50x20x 63-AD+B	63	20	52	50.05.20.60	BT50x20x 80-AD+B	80	20	52
50.01.25.6	SK50x25x 80-AD+B	80	25	64	50.05.25.60	BT50x25x100-AD+B	100	25	64
50.01.32.6	SK50x32x100-AD+B	100	32	72	50.05.32.60	BT50x32x120-AD+B	120	32	72
50.01.40.6	SK50x40x100-AD+B	100	40	80	50.05.40.60	BT50x40x120-AD+B	120	40	80
50.01.50.6	SK50x50x120-AD+B	120	50	100	50.05.50.60	BT50x50x125-AD+B	125	50	100

Zylinderschaftaufnahmen Weldon DIN 1835 B mit Kühlkanal Holders for straight shank tools Weldon DIN 1835 B with coolant channel

Kegelwinkel AT3, Rundlaufgenauigkeit SK zu Werkzeugaufnahme < 0,005
Taper angle AT3, Concentricity from the taper to the holding part < 0,005

Spannschrauben siehe Seite 46
Clamping nuts see page 46

SK30/BT30 G 2,5 - 25.000 U/min. oder U < 1 gmm
SK40/BT40 G 2,5 - 20.000 U/min. oder U < 1 gmm
SK50/BT50 G 2,5 - 15.000 U/min. oder U < 1 gmm

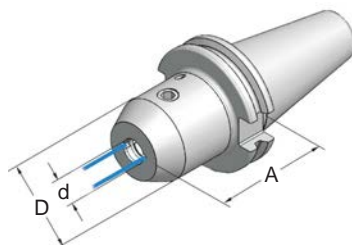

Für Werkzeuge mit innerer Kühlmittelzufuhr muss ein O-Ring separat bestellt werden! Siehe Seite 24

Für tools with through coolant a sealing ring must be ordered separately! See page 24

DIN 69871

MAS BT

Art.-Nr.	Typ	A	d	D	Art.-Nr.	Typ	A	d	D
					30.05.06.66	BT30x06x 60-AD+C	60	6	25
					30.05.08.66	BT30x08x 60-AD+C	60	8	28
					30.05.10.66	BT30x10x 60-AD+C	60	10	35
					30.05.12.66	BT30x12x 60-AD+C	60	12	42
					30.05.14.66	BT30x14x 60-AD+C	60	14	44
					30.05.16.66	BT30x16x 60-AD+C	60	16	48
					30.05.18.66	BT30x18x 60-AD+C	60	18	50
					30.05.20.66	BT30x20x 60-AD+C	60	20	52
40.01.06.66	SK40x06x 65-AD+B+C	65	6	25	40.05.06.66	BT40x06x 65-AD+B+C	65	6	25
40.01.08.66	SK40x08x 65-AD+B+C	65	8	28	40.05.08.66	BT40x08x 65-AD+B+C	65	8	28
40.01.10.66	SK40x10x 65-AD+B+C	65	10	35	40.05.10.66	BT40x10x 65-AD+B+C	65	10	35
40.01.12.66	SK40x12x 65-AD+B+C	65	12	42	40.05.12.66	BT40x12x 65-AD+B+C	65	12	42
40.01.14.66	SK40x14x 65-AD+B+C	65	14	44	40.05.14.66	BT40x14x 65-AD+B+C	65	14	44
40.01.16.66	SK40x16x 65-AD+B+C	65	16	48	40.05.16.66	BT40x16x 65-AD+B+C	65	16	48
40.01.18.66	SK40x18x 65-AD+B+C	65	18	50	40.05.18.66	BT40x18x 65-AD+B+C	65	18	50
40.01.20.66	SK40x20x 65-AD+B+C	65	20	52	40.05.20.66	BT40x20x 65-AD+B+C	65	20	52
40.01.25.66	SK40x25x 75-AD+B+C	75	25	64	40.05.25.66	BT40x25x 75-AD+B+C	75	25	64
40.01.32.66	SK40x32x 75-AD+B+C	75	32	72	40.05.32.66	BT40x32x 75-AD+B+C	75	32	72
40.01.06.662	SK40x06x100-AD+B+C	100	6	25	40.05.06.662	BT40x06x100-AD+B+C	100	6	25
40.01.08.662	SK40x08x100-AD+B+C	100	8	28	40.05.08.662	BT40x08x100-AD+B+C	100	8	28
40.01.10.662	SK40x10x100-AD+B+C	100	10	35	40.05.10.662	BT40x10x100-AD+B+C	100	10	35
40.01.12.662	SK40x12x100-AD+B+C	100	12	42	40.05.12.662	BT40x12x100-AD+B+C	100	12	42
40.01.16.662	SK40x16x100-AD+B+C	100	16	48	40.05.16.662	BT40x16x100-AD+B+C	100	16	48
40.01.20.662	SK40x20x100-AD+B+C	100	20	52	40.05.20.662	BT40x20x100-AD+B+C	100	20	52
40.01.25.662	SK40x25x100-AD+B+C	100	25	64	40.05.25.662	BT40x25x100-AD+B+C	100	25	64
40.01.32.662	SK40x32x100-AD+B+C	100	32	72	40.05.32.662	BT40x32x100-AD+B+C	100	32	72
50.01.06.66	SK50x06x100-AD+B+C	100	6	25	50.05.06.66	BT50x06x100-AD+B+C	100	6	25
50.01.08.66	SK50x08x100-AD+B+C	100	8	28	50.05.08.66	BT50x08x100-AD+B+C	100	8	28
50.01.10.66	SK50x10x100-AD+B+C	100	10	35	50.05.10.66	BT50x10x100-AD+B+C	100	10	35
50.01.12.66	SK50x12x100-AD+B+C	100	12	42	50.05.12.66	BT50x12x100-AD+B+C	100	12	42
50.01.14.66	SK50x14x100-AD+B+C	100	14	44	50.05.14.66	BT50x14x100-AD+B+C	100	14	44
50.01.16.66	SK50x16x100-AD+B+C	100	16	48	50.05.16.66	BT50x16x100-AD+B+C	100	16	48
50.01.18.66	SK50x18x100-AD+B+C	100	18	50	50.05.18.66	BT50x18x100-AD+B+C	100	18	50
50.01.20.66	SK50x20x100-AD+B+C	100	20	52	50.05.20.66	BT50x20x100-AD+B+C	100	20	52
50.01.25.66	SK50x25x100-AD+B+C	100	25	64	50.05.25.66	BT50x25x100-AD+B+C	100	25	64
50.01.32.66	SK50x32x100-AD+B+C	100	32	72	50.05.32.66	BT50x32x120-AD+B+C	120	32	72
50.01.40.66	SK50x40x100-AD+B+C	100	40	80	50.05.40.66	BT50x40x120-AD+B+C	120	40	80
50.01.50.66	SK50x50x120-AD+B+C	120	50	100	50.05.50.66	BT50x50x165-AD+B+C	165	50	100
50.01.10.663	SK50x10x160-AD+B+C	160	10	35	50.05.10.663	BT50x10x160-AD+B+C	160	10	35
50.01.12.663	SK50x12x160-AD+B+C	160	12	42	50.05.12.663	BT50x12x160-AD+B+C	160	12	42
50.01.16.663	SK50x16x160-AD+B+C	160	16	48	50.05.16.663	BT50x16x160-AD+B+C	160	16	48
50.01.20.663	SK50x20x160-AD+B+C	160	20	52	50.05.20.663	BT50x20x160-AD+B+C	160	20	52
50.01.25.663	SK50x25x160-AD+B+C	160	25	64	50.05.25.663	BT50x25x160-AD+B+C	160	25	64

Zylinderschaftaufnahmen Whistle-Notch DIN 1835 E

Holder for straight shank tools Whistle-Notch DIN 1835 E

Kegelwinkel AT3, Rundlaufgenauigkeit SK zu Werkzeugaufnahme < 0,005

Taper angle AT3, Concentricity from the taper to the holding part < 0,005

Spannschrauben siehe Seite 46

Clamping nuts see page 46

SK30/BT30 G 2,5 - 25.000 U/min. oder U < 1 gmm

SK40/BT40 G 2,5 - 20.000 U/min. oder U < 1 gmm

SK50/BT50 G 2,5 - 15.000 U/min. oder U < 1 gmm

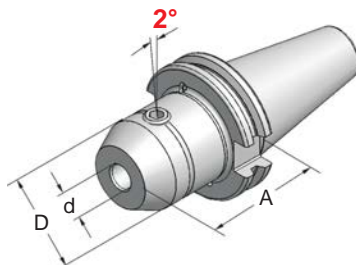

DIN 69871

MAS BT

Art.-Nr.	Typ	A	d	D	Art.-Nr.	Typ	A	d	D
					30.05.06.65	BT30x06Ex65-AD	65	6	25
					30.05.08.65	BT30x08Ex65-AD	65	8	28
					30.05.10.65	BT30x10Ex65-AD	65	10	35
					30.05.12.65	BT30x12Ex65-AD	65	12	42
					30.05.14.65	BT30x14Ex65-AD	65	14	44
					30.05.16.65	BT30x16Ex65-AD	65	16	48
					30.05.20.65	BT30x20Ex65-AD	65	20	52
40.01.06.65	SK40x06Ex 65-AD+B	65	6	25	40.05.06.65	BT40x06Ex 65-AD+B	65	6	25
40.01.08.65	SK40x08Ex 65-AD+B	65	8	28	40.05.08.65	BT40x08Ex 65-AD+B	65	8	28
40.01.10.65	SK40x10Ex 65-AD+B	65	10	35	40.05.10.65	BT40x10Ex 65-AD+B	65	10	35
40.01.12.65	SK40x12Ex 65-AD+B	65	12	42	40.05.12.65	BT40x12Ex 65-AD+B	65	12	42
40.01.14.65	SK40x14Ex 65-AD+B	65	14	44	40.05.14.65	BT40x14Ex 65-AD+B	65	14	44
40.01.16.65	SK40x16Ex 65-AD+B	65	16	48	40.05.16.65	BT40x16Ex 65-AD+B	65	16	48
40.01.18.65	SK40x18Ex 65-AD+B	65	18	50	40.05.18.65	BT40x18Ex 65-AD+B	65	18	50
40.01.20.65	SK40x20Ex 65-AD+B	65	20	52	40.05.20.65	BT40x20Ex 65-AD+B	65	20	52
40.01.25.65	SK40x25Ex 75-AD+B	75	25	63	40.05.25.65	BT40x25Ex 75-AD+B	75	25	63
40.01.32.65	SK40x32Ex 75-AD+B	75	32	63	40.05.32.65	BT40x32Ex 75-AD+B	75	32	63
40.01.06.652	SK40x06Ex100-AD+B	100	6	25	40.05.06.652	BT40x06Ex100-AD+B	100	6	25
40.01.08.652	SK40x08Ex100-AD+B	100	8	28	40.05.08.652	BT40x08Ex100-AD+B	100	8	28
40.01.10.652	SK40x10Ex100-AD+B	100	10	35	40.05.10.652	BT40x10Ex100-AD+B	100	10	35
40.01.12.652	SK40x12Ex100-AD+B	100	12	42	40.05.12.652	BT40x12Ex100-AD+B	100	12	42
40.01.14.652	SK40x14Ex100-AD+B	100	14	44	40.05.14.652	BT40x14Ex100-AD+B	100	14	44
40.01.16.652	SK40x16Ex100-AD+B	100	16	48	40.05.16.652	BT40x16Ex100-AD+B	100	16	48
40.01.20.652	SK40x20Ex100-AD+B	100	20	52	40.05.20.652	BT40x20Ex100-AD+B	100	20	52
50.01.06.65	SK50x06Ex 63-AD+B	63	6	25	50.05.06.65	BT50x06Ex 63-AD+B	63	6	25
50.01.08.65	SK50x08Ex 63-AD+B	63	8	28	50.05.08.65	BT50x08Ex 63-AD+B	63	8	28
50.01.10.65	SK50x10Ex 63-AD+B	63	10	35	50.05.10.65	BT50x10Ex 63-AD+B	63	10	35
50.01.12.65	SK50x12Ex 63-AD+B	63	12	42	50.05.12.65	BT50x12Ex 80-AD+B	80	12	42
50.01.14.65	SK50x14Ex 63-AD+B	63	14	44	50.05.14.65	BT50x14Ex 80-AD+B	80	14	44
50.01.16.65	SK50x16Ex 63-AD+B	63	16	48	50.05.16.65	BT50x16Ex 80-AD+B	80	16	48
50.01.18.65	SK50x18Ex 63-AD+B	63	18	50	50.05.18.65	BT50x18Ex 80-AD+B	80	18	50
50.01.20.65	SK50x20Ex 63-AD+B	63	20	52	50.05.20.65	BT50x20Ex 80-AD+B	80	20	52
50.01.25.65	SK50x25Ex 80-AD+B	80	25	63	50.05.25.65	BT50x25Ex100-AD+B	100	25	63
50.01.32.65	SK50x32Ex100-AD+B	100	32	63	50.05.32.65	BT50x32Ex105-AD+B	105	32	63

Reduziereinsätze für Werkzeugschäfte nach DIN 1835 Form B & Form E
Reducing bushings for toolshanks DIN 1835 B and E

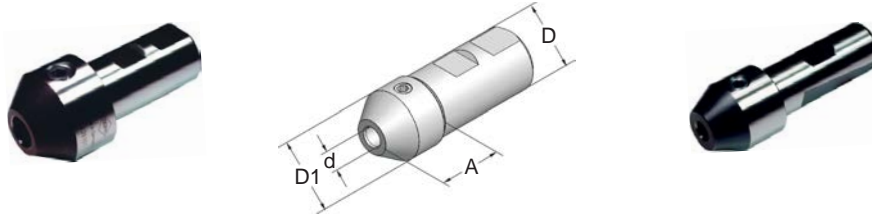

Weldon

Whistle-Notch

Art.-Nr.	Typ	A	d	D	D1	Art.-Nr.	Typ	A	d	D	D1
437101	ø20x06	29	6	20	25	441101	ø20x06	29	6	20	25
438101	ø20x08	29	8	20	28	442101	ø20x08	29	8	20	28
439101	ø20x10	29	10	20	35	443101	ø20x10	29	10	20	35
440101	ø20x12	35	12	20	42	444101	ø20x12	35	12	20	42
421101	ø32x06	27	6	32	25	429101	ø32x06	27	6	32	25
422101	ø32x08	27	8	32	28	430101	ø32x08	27	8	32	28
423101	ø32x10	30	10	32	35	431101	ø32x10	30	10	32	35
424101	ø32x12	35	12	32	42	432101	ø32x12	35	12	32	42
425101	ø32x14	35	14	32	44	433101	ø32x14	35	14	32	44
426101	ø32x16	38	16	32	48	434101	ø32x16	38	16	32	48
427101	ø32x18	38	18	32	50	435101	ø32x18	38	18	32	50
428101	ø32x20	40	20	32	52	436101	ø32x20	40	20	32	52

Gewindeschneidfutter für Spannzangen ER/ESX
Tapping head for collets ER/ESX

Längenausgleich auf Druck + Zug
Flexible position for compression and tension

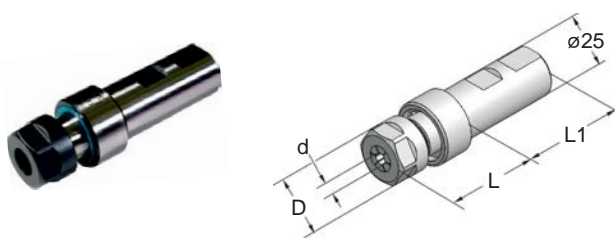

Weldon ø25

Art.-Nr.	Typ	d	D	L	L1
25.12.13	ø32x1-10	1-10	32	45	56

O-Ringe für Zylinderschaftaufnahme Weldon DIN 1835 B mit Kühlkanal (siehe Seite 22)
Sealing rings for holders for straight shank tools Weldon DIN 1835 B with through tool coolant channel (see page 22)



O-Ring

O-Ring

Art.-Nr.	Typ	Art.-Nr.	Typ
270100	6,0 x 1,5	276100	18,0 x 2,5
271100	8,0 x 1,5	277100	20,0 x 2,5
272100	10,0 x 2,0	278100	25,0 x 3,0
273100	12,0 x 2,0	279100	32,0 x 3,0
274100	14,0 x 2,0	299100	40,0 x 3,5
275100	16,0 x 2,5	300100	50,0 x 3,5

NC-Bohrfutter für Rechts- und Linkslauf CNC-Drill chucks for clockwise and anti-clockwise rotation

Kegelwinkel AT3, Rundlaufgenauigkeit SK zu Werkzeugaufnahme < 0,04
Taper angle AT3, Concentricity from the taper to the holding part < 0,04

Grundkörper gewuchtet G 2,5 - 8.000 U/min.
Base-body balanced G 2,5 - 8.000 r.p.m

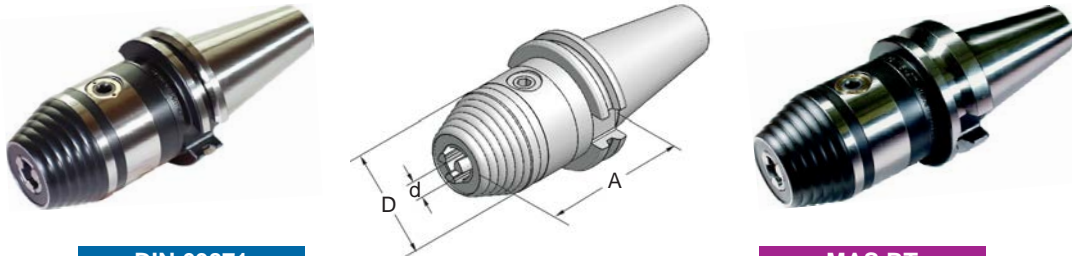

DIN 69871

MAS BT

Art.-Nr.	Typ	A	d	D	Art.-Nr.	Typ	A	d	D
30.01.08	SK30x1 - 8x70	70	1 - 8	36	30.05.08	BT30x1 - 8x 73	73	1 - 8	36
30.01.13	SK30x1-13x90	90	1-13	50					
40.01.13	SK40x1-13x90	90	1-13	50	40.05.13	BT40x1-13x 97	97	1-13	50
40.01.16	SK40x3-16x90	90	3-16	57	40.05.16	BT40x3-16x 97	97	3-16	57
40.01.13k	SK40x1-13x90-AD+B	90	1-13	50	40.05.13k	BT40x1-13x 97-AD+B	97	1-13	50
40.01.16k	SK40x3-16x90-AD+B	90	3-16	57	40.05.16k	BT40x3-16x 97-AD+B	97	3-16	57
50.01.13	SK50x1-13x90	90	1-13	50	50.05.13	BT50x1-13x108	108	1-13	50
50.01.16	SK50x3-16x90	90	3-16	57	50.05.16	BT50x3-16x108	108	3-16	57
50.01.13k	SK50x1-13x90-AD+B	90	1-13	50	50.05.13k	BT50x1-13x108-AD+B	108	1-13	50
50.01.16k	SK50x3-16x90-AD+B	90	3-16	57	50.05.16k	BT50x3-16x108-AD+B	108	3-16	57

Bohrfutteraufnahmen DIN 238 Drill chuck arbors DIN 238

Kegelwinkel AT3, Rundlaufgenauigkeit SK zu Werkzeugaufnahme < 0,005
Taper angle AT3, Concentricity from the taper to the holding part < 0,005

*Das Bohrfutter muss separat bestellt werden!
The drill chuck has to be ordered separately!*

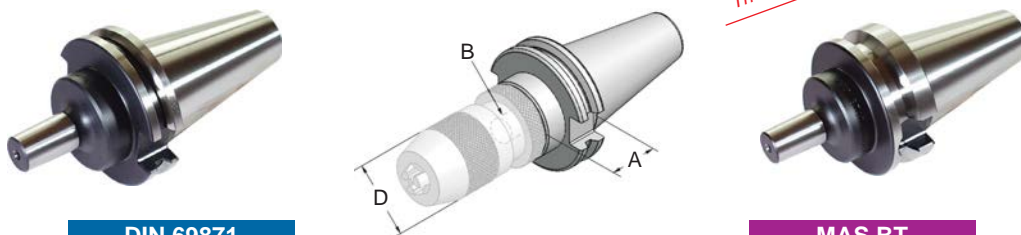

DIN 69871

MAS BT

Art.-Nr.	Typ	A	B	D	Art.-Nr.	Typ	A	B	D
30.01.12.8	SK30xB12	23	12	43	30.05.12.8	BT30xB12	26	12	43
30.01.16.8	SK30xB16	24	16	50	30.05.16.8	BT30xB16	27	16	50
40.01.12.8	SK40xB12	35	12	43	40.05.12.8	BT40xB12	43	12	43
40.01.16.8	SK40xB16	36	16	50	40.05.16.8	BT40xB16	44	16	50
50.01.16.8	SK50xB12	25	16	50	50.05.16.8	BT50xB12	43	16	50
50.01.18.8	SK50xB16	25	18	56	50.05.18.8	BT50xB16	43	18	56

Bohrfutter Drill chucks



Typ B12

Typ B16

Art.-Nr.	Typ	Art.-Nr.	Typ
287100	B12xø0,5-10x80	289100	B16xø1,0-13x90
		290100	B16xø2,5-16x95

Schrumpffutter **POWER-FLASH** high-speed Shrinking chucks **POWER-FLASH** high-speed

Optimale Kühlmittelzufuhr über Kühlkanäle in der Bohrung
Konzentrierte Kühlmittelzufuhr bis 20.000 U/min zur Werkzeugschneide
Best possible coolant supply through coolant channels in the boring
Concentrated coolant supply up to 20.000 r.p.m. to the cutting edge

BT30 G 2,5 - 25.000 U/min. oder U < 1 gmm
SK40/BT40 G 2,5 - 20.000 U/min. oder U < 1 gmm

Lieferumfang ohne Werkzeug
Delivery without tool

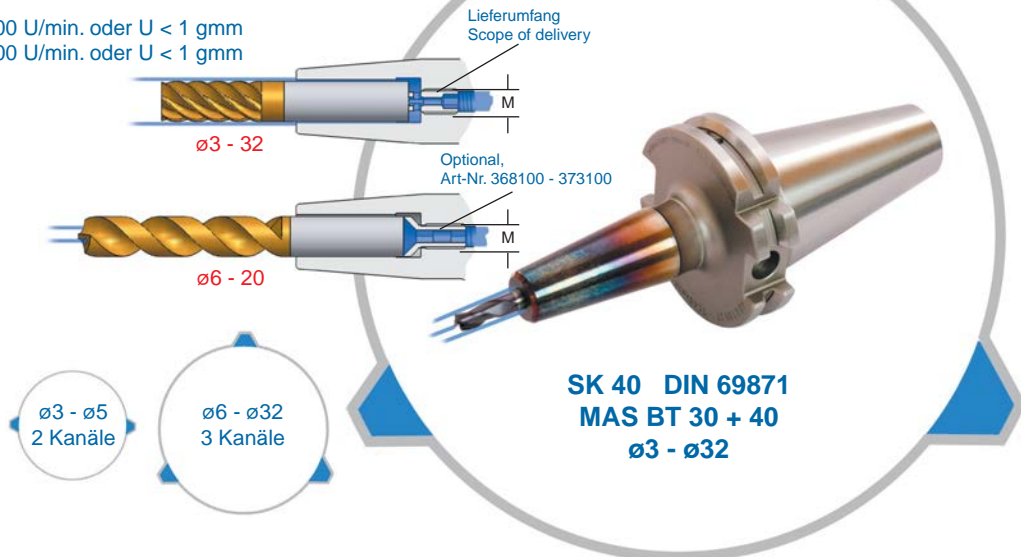

Anschlagschraube Stop screw

Art.-Nr.	d	M
368100	ø6	M 8x1
369100	ø8	M 8x1
370100	ø10	M10x1
371100	ø12	M10x1
372100	ø16	M10x1
373100	ø20	M10x1

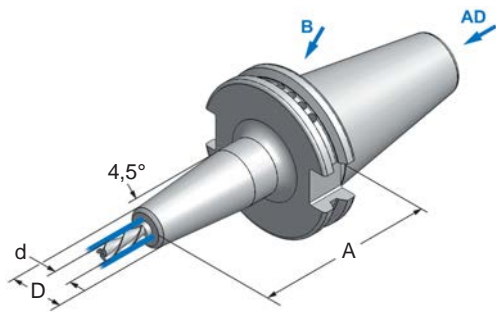

DIN 69871

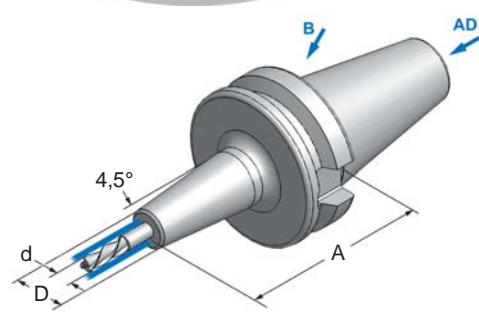

MAS BT

Art.-Nr.	Typ	A	d	D	M	Art.-Nr.	Typ	A	d	D	M
40.01.03.37	SK40x03SCx 80-AD+B	80	3	10	M6	30.05.03.37	BT30x03SCx 70-AD	70	3	10	M6
40.01.04.37	SK40x04SCx 80-AD+B	80	4	11	M6	30.05.04.37	BT30x04SCx 70-AD	70	4	11	M6
40.01.05.37	SK40x05SCx 80-AD+B	80	5	14	M8x1	30.05.05.37	BT30x05SCx 70-AD	70	5	14	M8x1
40.01.06.37	SK40x06SCx 80-AD+B	80	6	16	M8x1	30.05.06.37	BT30x06SCx 70-AD	70	6	21	M8x1
40.01.08.37	SK40x08SCx 80-AD+B	80	8	21	M8x1	30.05.08.37	BT30x08SCx 70-AD	70	8	21	M8x1
40.01.10.37	SK40x10SCx 80-AD+B	80	10	24	M10x1	30.05.10.37	BT30x10SCx 70-AD	70	10	24	M10x1
40.01.12.37	SK40x12SCx 80-AD+B	80	12	24	M10x1	30.05.12.37	BT30x12SCx 70-AD	70	12	24	M10x1
40.01.16.37	SK40x16SCx 80-AD+B	80	16	27	M10x1	30.05.16.37	BT30x16SCx 70-AD	70	16	27	M10x1
40.01.20.37	SK40x20SCx 80-AD+B	80	20	33	M10x1	30.05.20.37	BT30x20SCx 70-AD	70	20	33	M10x1
40.01.25.37	SK40x25SCx100-AD+B	100	25	44	M10x1						
40.01.32.37	SK40x32SCx100-AD+B	100	32	44	M10x1	40.05.03.37	BT40x03SCx 80-AD+B	80	3	10	M6
						40.05.04.37	BT40x04SCx 80-AD+B	80	4	11	M6
						40.05.05.37	BT40x05SCx 80-AD+B	80	5	14	M8x1
						40.05.06.37	BT40x06SCx 80-AD+B	80	6	16	M8x1
						40.05.08.37	BT40x08SCx 80-AD+B	80	8	21	M8x1
						40.05.10.37	BT40x10SCx 80-AD+B	80	10	24	M10x1
						40.05.12.37	BT40x12SCx 80-AD+B	80	12	24	M10x1
						40.05.16.37	BT40x16SCx 80-AD+B	80	16	27	M10x1
						40.05.20.37	BT40x20SCx 80-AD+B	80	20	33	M10x1
						40.05.25.37	BT40x25SCx100-AD+B	100	25	44	M10x1
						40.05.32.37	BT40x32SCx100-AD+B	100	32	44	M10x1

Schrumpffutter mit verschließbaren Kühlkanälen Shrinking chucks with lockable coolant channels

Kegelwinkel AT3, Rundlaufgenauigkeit SK zu Werkzeugaufnahme < 0,005
Taper angle AT3, Concentricity from the taper to the holding part < 0,005

SK40/BT40 G 2,5 - 20.000 U/min. oder U < 1 gmm
SK50/BT50 G 2,5 - 15.000 U/min. oder U < 1 gmm

Lieferumfang ohne Werkzeug
Delivery without tool

Verschluss der Kühlmittelzufuhr für Werkzeuge mit Innenkühlung

Seal of the coolant supply for tools with internal cooling

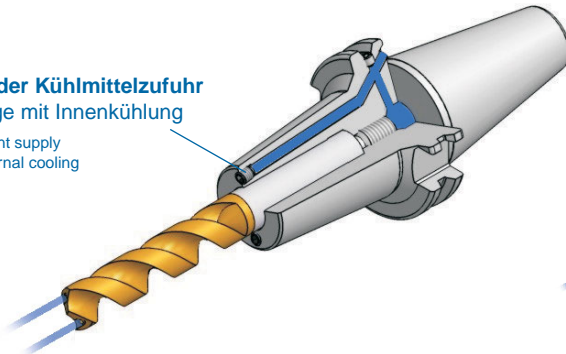

Eingeschraubte Düsen garantieren konzentrierten Kühlmittelstrahl zur Schneide

Screwed in coolant nozzles guarantee concentrated jet of coolant to the edge

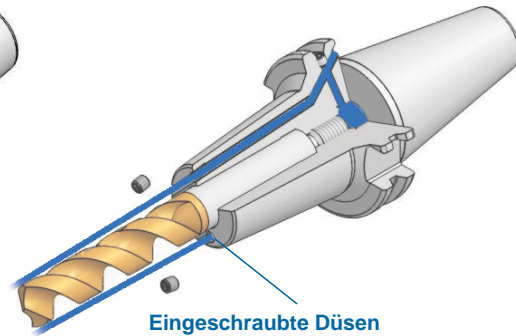

*Sonderausführungen auf Anfrage
Special executions on inquiry*

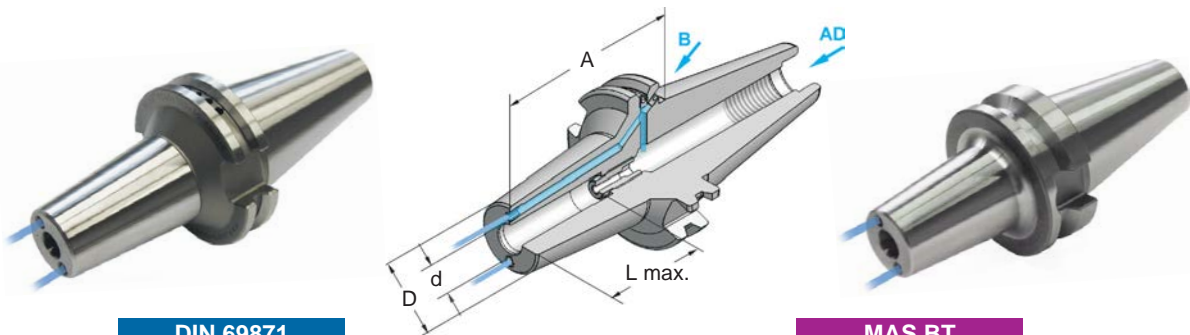

DIN 69871

MAS BT

Art.-Nr.	Typ	A	d	D	L	Art.-Nr.	Typ	A	d	D	L
40.01.08.36	SK40x08Sx 80-AD+B+C	80	8	24	40	40.05.08.36	BT40x08Sx 80-AD+B+C	80	8	24	40
40.01.10.36	SK40x10Sx 80-AD+B+C	80	10	26	42	40.05.10.36	BT40x10Sx 80-AD+B+C	80	10	26	42
40.01.12.36	SK40x12Sx 80-AD+B+C	80	12	28	47	40.05.12.36	BT40x12Sx 80-AD+B+C	80	12	28	47
40.01.14.36	SK40x14Sx 80-AD+B+C	80	14	30	47	40.05.14.36	BT40x14Sx 80-AD+B+C	80	14	30	47
40.01.16.36	SK40x16Sx 80-AD+B+C	80	16	32	50	40.05.16.36	BT40x16Sx 80-AD+B+C	80	16	32	50
40.01.18.36	SK40x18Sx 80-AD+B+C	80	18	34	50	40.05.18.36	BT40x18Sx 80-AD+B+C	80	18	34	50
40.01.20.36	SK40x20Sx 80-AD+B+C	80	20	36	52	40.05.20.36	BT40x20Sx 80-AD+B+C	80	20	36	52
40.01.25.36	SK40x25Sx 90-AD+B+C	90	25	42	58	40.05.25.36	BT40x25Sx 90-AD+B+C	90	25	42	58
50.01.08.36	SK50x08Sx100-AD+B+C	100	8	24	40	50.05.08.36	BT50x08Sx100-AD+B+C	100	8	24	40
50.01.10.36	SK50x10Sx100-AD+B+C	100	10	26	42	50.05.10.36	BT50x10Sx100-AD+B+C	100	10	26	42
50.01.12.36	SK50x12Sx100-AD+B+C	100	12	28	47	50.05.12.36	BT50x12Sx100-AD+B+C	100	12	28	47
50.01.14.36	SK50x14Sx100-AD+B+C	100	14	30	47	50.05.14.36	BT50x14Sx100-AD+B+C	100	14	30	47
50.01.16.36	SK50x16Sx100-AD+B+C	100	16	32	50	50.05.16.36	BT50x16Sx100-AD+B+C	100	16	32	50
50.01.20.36	SK50x20Sx100-AD+B+C	100	20	36	52	50.05.20.36	BT50x20Sx100-AD+B+C	100	20	36	52
50.01.25.36	SK50x25Sx100-AD+B+C	100	25	42	58	50.05.25.36	BT50x25Sx100-AD+B+C	100	25	42	58
50.01.32.36	SK50x32Sx100-AD+B+C	100	32	49	58	50.05.32.36	BT50x32Sx100-AD+B+C	100	32	49	58
50.01.10.362	SK50x10Sx130-AD+B+C	130	10	26	42						
50.01.12.362	SK50x12Sx130-AD+B+C	130	12	28	47						
50.01.16.362	SK50x16Sx130-AD+B+C	130	16	32	50						
50.01.20.362	SK50x20Sx130-AD+B+C	130	20	36	52						
50.01.25.362	SK50x25Sx130-AD+B+C	130	25	42	58						
50.01.32.362	SK50x32Sx130-AD+B+C	130	32	49	58						

Schrumpffutter ohne Kühlkanäle Shrinking chucks without coolant channels

Kegelwinkel AT3, Rundlaufgenauigkeit SK zu Werkzeugaufnahme < 0,005
Taper angle AT3, Concentricity from the taper to the holding part < 0,005

SK25+30/BT30 G 2,5 - 25.000 U/min. oder U < 1 gmm
SK40/BT40 G 2,5 - 20.000 U/min. oder U < 1 gmm

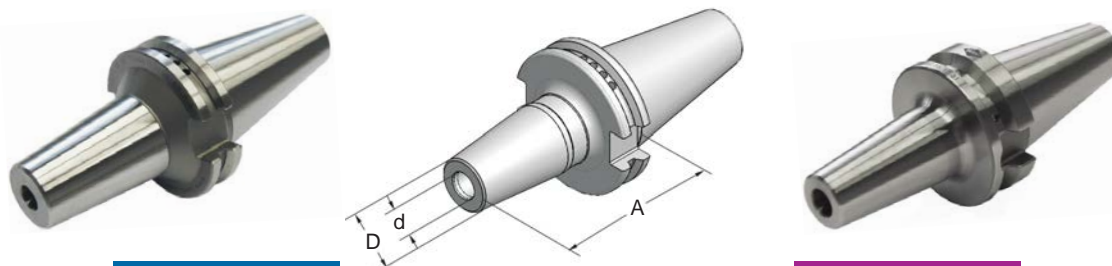

DIN 69871

MAS BT

Art.-Nr.	Typ	A	d	D	Art.-Nr.	Typ	A	d	D
25.01.03.31	SK25x03Sx60-AD	60	3	10	30.05.03.31	BT30x03Sx70-AD	70	3	10
25.01.04.31	SK25x04Sx60-AD	60	4	11	30.05.04.31	BT30x04Sx70-AD	70	4	10
25.01.06.31	SK25x06Sx60-AD	60	6	21	30.05.05.31	BT30x05Sx70-AD	70	5	14
25.01.08.31	SK25x08Sx60-AD	60	8	21	30.05.06.31	BT30x06Sx70-AD	70	6	21
25.01.10.31	SK25x10Sx60-AD	60	10	21	30.05.08.31	BT30x08Sx70-AD	70	8	21
	SK25 mit Plananlage				30.05.10.31	BT30x10Sx70-AD	70	10	24
					30.05.12.31	BT30x12Sx70-AD	70	12	24
30.01.03.31	SK30x03Sx70-AD	70	3	10	30.05.14.31	BT30x14Sx70-AD	70	14	27
30.01.04.31	SK30x04Sx70-AD	70	4	11	30.05.16.31	BT30x16Sx70-AD	70	16	27
30.01.05.31	SK30x05Sx70-AD	70	5	14	30.05.20.31	BT30x20Sx70-AD	70	20	33
30.01.06.31	SK30x06Sx70-AD	70	6	21					
30.01.08.31	SK30x08Sx70-AD	70	8	21	40.05.03.31	BT40x03Sx 80-AD+B	80	3	10
30.01.10.31	SK30x10Sx70-AD	70	10	24	40.05.04.31	BT40x04Sx 80-AD+B	80	4	11
30.01.12.31	SK30x12Sx70-AD	70	12	24	40.05.05.31	BT40x05Sx 80-AD+B	80	5	14
30.01.14.31	SK30x14Sx70-AD	70	14	27	40.05.06.31	BT40x06Sx 90-AD+B	90	6	21
30.01.16.31	SK30x16Sx70-AD	70	16	27	40.05.08.31	BT40x08Sx 90-AD+B	90	8	21
					40.05.10.31	BT40x10Sx 90-AD+B	90	10	24
40.01.03.31	SK40x03Sx 80-AD+B	80	3	10	40.05.12.31	BT40x12Sx 90-AD+B	90	12	24
40.01.04.31	SK40x04Sx 80-AD+B	80	4	11	40.05.14.31	BT40x14Sx 90-AD+B	90	14	27
40.01.05.31	SK40x05Sx 80-AD+B	80	5	14	40.05.16.31	BT40x16Sx 90-AD+B	90	16	27
40.01.06.31	SK40x06Sx 80-AD+B	80	6	21	40.05.18.31	BT40x18Sx 90-AD+B	90	18	33
40.01.08.31	SK40x08Sx 80-AD+B	80	8	21	40.05.20.31	BT40x20Sx 90-AD+B	90	20	33
40.01.10.31	SK40x10Sx 80-AD+B	80	10	24	40.05.25.31	BT40x25Sx100-AD+B	100	25	44
40.01.12.31	SK40x12Sx 80-AD+B	80	12	24	40.05.32.31	BT40x32Sx100-AD+B	100	32	44
40.01.14.31	SK40x14Sx 80-AD+B	80	14	27					
40.01.16.31	SK40x16Sx 80-AD+B	80	16	27					
40.01.18.31	SK40x18Sx 80-AD+B	80	18	33					
40.01.20.31	SK40x20Sx 80-AD+B	80	20	33					
40.01.25.31	SK40x25Sx100-AD+B	100	25	44					
40.01.32.31	SK40x32Sx100-AD+B	100	32	44					
40.01.06.32	SK40x06Sx130-AD+B	130	6	21					
40.01.08.32	SK40x08Sx130-AD+B	130	8	21					
40.01.10.32	SK40x10Sx130-AD+B	130	10	24					
40.01.12.32	SK40x12Sx130-AD+B	130	12	24					
40.01.16.32	SK40x16Sx130-AD+B	130	16	27					
40.01.20.32	SK40x20Sx130-AD+B	130	20	33					
40.01.25.32	SK40x25Sx130-AD+B	130	25	44					
40.01.32.32	SK40x32Sx130-AD+B	130	32	44					
40.01.06.33	SK40x06Sx160-AD+B	160	6	21					
40.01.08.33	SK40x08Sx160-AD+B	160	8	21					
40.01.10.33	SK40x10Sx160-AD+B	160	10	24					
40.01.12.33	SK40x12Sx160-AD+B	160	12	24					
40.01.14.33	SK40x14Sx160-AD+B	160	14	27					
40.01.16.33	SK40x16Sx160-AD+B	160	16	27					
40.01.18.33	SK40x18Sx160-AD+B	160	18	33					
40.01.20.33	SK40x20Sx160-AD+B	160	20	33					

Schrumpffutter ohne Kühlkanäle

Shrinking chucks without coolant channels

Kegelwinkel AT3, Rundlaufgenauigkeit SK zu Werkzeugaufnahme < 0,005
Taper angle AT3, Concentricity from the taper to the holding part < 0,005

SK50/BT50 G 2,5 - 15.000 U/min. oder U < 1 gmm

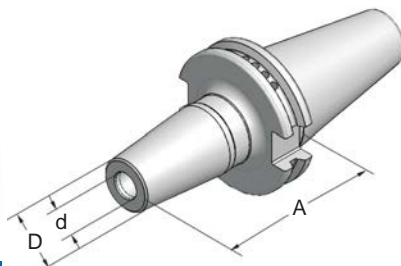

DIN 69871

MAS BT

Art.-Nr.	Typ	A	d	D	Art.-Nr.	Typ	A	d	D
50.01.06.31	SK50x06Sx 80-AD+B	80	6	21	50.05.06.31	BT50x06Sx 80-AD+B	80	6	21
50.01.08.31	SK50x08Sx 80-AD+B	80	8	21	50.05.08.31	BT50x08Sx 80-AD+B	80	8	21
50.01.10.31	SK50x10Sx 80-AD+B	80	10	24	50.05.10.31	BT50x10Sx 80-AD+B	80	10	24
50.01.12.31	SK50x12Sx 80-AD+B	80	12	24	50.05.12.31	BT50x12Sx 80-AD+B	80	12	24
50.01.14.31	SK50x14Sx 80-AD+B	80	14	27	50.05.14.31	BT50x14Sx 80-AD+B	80	14	27
50.01.16.31	SK50x16Sx 80-AD+B	80	16	27	50.05.16.31	BT50x16Sx 80-AD+B	80	16	27
50.01.20.31	SK50x20Sx 80-AD+B	80	20	33	50.05.20.31	BT50x20Sx 80-AD+B	80	20	33
50.01.25.31	SK50x25Sx100-AD+B	100	25	44	50.05.25.31	BT50x25Sx100-AD+B	100	25	44
50.01.32.31	SK50x32Sx100-AD+B	100	32	44	50.05.32.31	BT50x32Sx100-AD+B	100	32	44
50.01.06.32	SK50x06Sx130-AD+B	130	6	21					
50.01.08.32	SK50x08Sx130-AD+B	130	8	21					
50.01.10.32	SK50x10Sx130-AD+B	130	10	24					
50.01.12.32	SK50x12Sx130-AD+B	130	12	24					
50.01.14.32	SK50x14Sx130-AD+B	130	14	27					
50.01.16.32	SK50x16Sx130-AD+B	130	16	27					
50.01.20.32	SK50x20Sx130-AD+B	130	20	33					
50.01.25.32	SK50x25Sx130-AD+B	130	25	44					
50.01.32.32	SK50x32Sx130-AD+B	130	32	44					

Dehnspannfutter Expansion chucks

Kegelwinkel AT3, Rundlaufgenauigkeit SK zu Werkzeugaufnahme < 0,003
Taper angle AT3, Concentricity from the taper to the holding part < 0,003

Grundkörper gewuchtet G 2,5 - 25.000 U/min.
Base-body balanced G 2,5 - 25.000 r.p.m

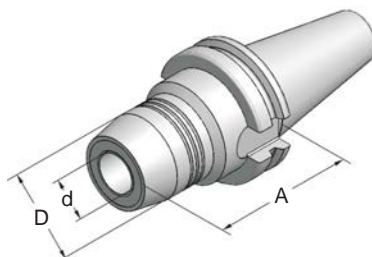

DIN 69871

MAS BT

Art.-Nr.	Typ	A	d	D	Art.-Nr.	Typ	A	d	D
40.01.06.70	SK40x06x80,5-AD+B	80,5	6	26	40.05.06.70	BT40x06x90,0-AD+B	90,0	6	26
40.01.08.70	SK40x08x80,5-AD+B	80,5	8	28	40.05.08.70	BT40x08x90,0-AD+B	90,0	8	28
40.01.10.70	SK40x10x80,5-AD+B	80,5	10	30	40.05.10.70	BT40x10x90,0-AD+B	90,0	10	30
40.01.12.70	SK40x12x80,5-AD+B	80,5	12	32	40.05.12.70	BT40x12x90,0-AD+B	90,0	12	32
40.01.16.70	SK40x16x80,5-AD+B	80,5	16	38	40.05.16.70	BT40x16x90,0-AD+B	90,0	16	38
40.01.20.70	SK40x20x80,5-AD+B	80,5	20	42	40.05.20.70	BT40x20x90,0-AD+B	90,0	20	42
40.01.20.71	SK40x20x64,5-AD+B	64,5	20	49	40.05.20.71	BT40x20x72,5-AD+B	72,5	20	49
40.01.25.70	SK40x25x80,5-AD+B	80,5	25	55					
40.01.32.70	SK40x32x80,5-AD+B	80,5	32	63	40.05.32.70	BT40x32x83,0-AD+B	83,0	32	63
50.01.20.70	SK50x20x80,5-AD+B	80,5	20	42	50.05.20.70	BT50x20x90,0-AD+B	90,0	20	42
50.01.32.71	SK50x32x81,0-AD+B	81,0	32	72	50.05.32.70	BT50x32x90,0-AD+B	90,0	32	72

Zwischenhülsen Sleeves



ø12

ø20

ø32

Art.-Nr.	Typ	Art.-Nr.	Typ	Art.-Nr.	Typ
204370	GZB-S 12/03	203197	GZB-S 20/03	204320	GZB-S 32/06
204371	GZB-S 12/04	203198	GZB-S 20/04	204321	GZB-S 32/08
204372	GZB-S 12/05	203199	GZB-S 20/05	204322	GZB-S 32/10
204373	GZB-S 12/06	203200	GZB-S 20/06	204323	GZB-S 32/12
204374	GZB-S 12/08	203201	GZB-S 20/08	204324	GZB-S 32/14
204375	GZB-S 12/10	203202	GZB-S 20/10	204325	GZB-S 32/16
		203203	GZB-S 20/12	204326	GZB-S 32/18
		203204	GZB-S 20/14	204327	GZB-S 32/20
		203205	GZB-S 20/16	204328	GZB-S 32/25

Werkzeugaufnahmen zur Kühlmittel- bzw. Luftzufuhr

Toolholders for coolant- and air supply

Kegelwinkel AT3, Rundlaufgenauigkeit SK zu Werkzeugaufnahme < 0,005
Taper angle AT3, Concentricity from the taper to the holding part < 0,005

max. U/min / max. r.p.m.: 3000
Kühlmitteldruck / Coolant pressure: max. 6 bar
Luftdruck / Air pressure: max. 4 bar

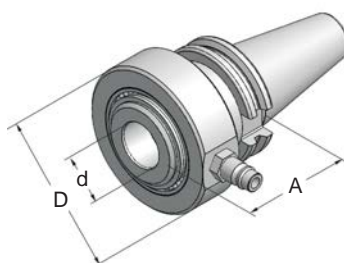

DIN 69871

MAS BT

Art.-Nr.	Typ	A	d	D	Art.-Nr.	Typ	A	d	D
40.01.25.68	SK40	65	25	80	40.05.25.68	BT40	58	25	80
40.01.32.68	SK40	65	32	80	40.05.32.68	BT40	58	32	80
50.01.25.68	SK50	65	25	80	50.05.25.68	BT50	69	25	80
50.01.32.68	SK50	65	32	80	50.05.32.68	BT50	69	32	80

Spannzangenfutter ER32 zur Kühlmittel- bzw. Luftzufuhr

Collet chuck ER32 for coolant- and air supply

Spannzangen siehe Seiten 48+49
Collets see pages 48+49

max. U/min / max. r.p.m.: 3000
Kühlmitteldruck / Coolant pressure: max. 6 bar
Luftdruck / Air pressure: max. 4 bar



Spannzange ER32
Collet ER32

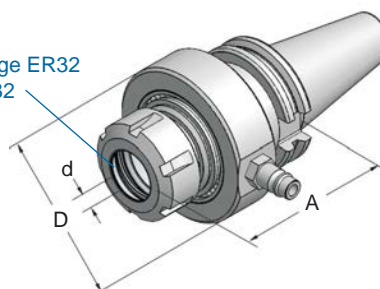

DIN 69871

Art.-Nr.	Typ	A	d	D
40.01.20.28	SK40	94	2-20	80

Gewindeschneidfutter für Spannzangen ER/ESX mit elastischem Längenausgleich auf Druck und Zug Tapping heads for collets ER/ESX with smooth-action length compensation for pressure and tension

Spannzangen siehe Seiten 48+49
Collets see pages 48+49



DIN 69871

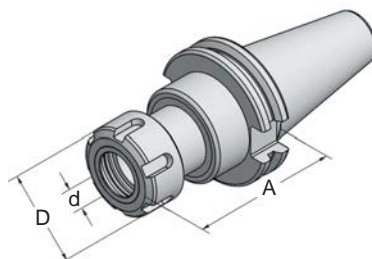

ER 16



MAS BT

Art.-Nr.	Typ	A	d	D	Art.-Nr.	Typ	A	d	D
30.01.12.13	SK30xER16x 70	70	1-10 für M2-M12	28	30.05.20.13	BT30xER25x 93	93	2-16 für M4-M20	42
40.01.12.13	SK40xER16x 65	65	1-10 für M2-M12	28	40.05.12.13	BT40xER16x 65	65	1-10 für M2-M12	28
40.01.20.13	SK40xER25x 78	78	2-16 für M4-M20	42	40.05.20.13	BT40xER25x 82	82	2-16 für M4-M20	42
40.01.24.13	SK40xER32x 94	94	3-20 für M6-M24	50	40.05.24.13	BT40xER32x 98	98	3-20 für M6-M24	50
40.01.33.13	SK40xER40x115	115	4-30 für M8-M33	63	40.05.33.13	BT40xER40x115	115	4-30 für M8-M33	63
45.01.20.13	SK45xER25x 98	98	2-16 für M4-M20	42	45.05.20.13	BT45xER25x 98	98	2-16 für M4-M20	42
45.01.33.13	SK45xER40x102	102	4-30 für M8-M33	63	45.05.33.13	BT45xER40x 95	95	4-30 für M8-M33	63
50.01.20.13	SK50xER25x100	100	2-16 für M4-M20	42	50.05.20.13	BT50xER25x100	100	2-16 für M4-M20	42
50.01.33.13	SK50xER40x102	102	4-30 für M8-M33	63	50.05.33.13	BT50xER40x100	100	4-30 für M8-M33	63

Gewindeschneid-Schnellwechselfutter mit elastischem Längenausgleich auf Druck und Zug Thread cutting quick-change chucks with smooth-action length compensation for pressure and tension



DIN 69871

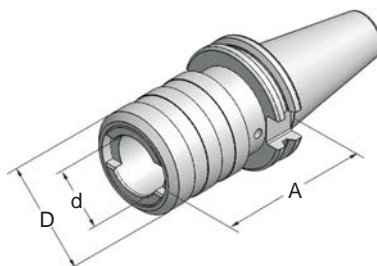

*Der Einsatz muss separat bestellt werden!
The tapping collet has to be ordered separately!*

MAS BT

Art.-Nr.	Typ	Größe	A	d	D	Art.-Nr.	Typ	Größe	A	d	D
30.01.12.130	SK30xM3-M14	1	65	19	38	30.05.12.130	BT30xM3-M14	1	62	19	38
40.01.12.130	SK40xM3-M14	1	59	19	38	40.05.12.130	BT40xM3-M14	1	65	19	38
50.01.12.130	SK50xM3-M14	1	63	19	38	50.05.12.130	BT50xM3-M14	1	100	19	38
30.01.20.130	SK30xM5-M24	2	99	31	54	30.05.20.130	BT30xM5-M24	2	95	31	54
40.01.20.130	SK40xM5-M24	2	97	31	54	40.05.20.130	BT40xM5-M24	2	93	31	54
50.01.20.130	SK50xM5-M24	2	97	31	54	50.05.20.130	BT50xM5-M24	2	100	31	54
40.01.33.130	SK30xM14-M36	3	156	48	78	40.05.33.130	BT40xM14-M36	3	166	48	78
50.01.33.130	SK50xM14-M36	3	140	48	78	50.05.33.130	BT50xM14-M36	3	142	48	78

Einsätze mit Rutschkupplung Tapping collets with clutch



Größe 1 M3-M14

Größe 2 M5-M24

Größe 3 M14-M36

Art.-Nr.	Typ	Art.-Nr.	Typ	Art.-Nr.	Typ
100035	ø 3,50 - M3+M4				
100040	ø 4,00 - M3,5				
100045	ø 4,50 - M4+M6				
100060	ø 6,00 - M5+M6+M8	200060	ø 6,00 - M5+M6+M8		
100070	ø 7,00 - M7+M9+M10	200070	ø 7,00 - M7+M9+M10		
100080	ø 8,00 - M8+M11	200080	ø 8,00 - M8+M11		
100090	ø 9,00 - M9+M12	200090	ø 9,00 - M9+M12		
100100	ø10,00 - M10	200100	ø10,00 - M10		
100110	ø11,00 - M14	200110	ø11,00 - M14	300110	ø11,00 - M14
		200120	ø12,00 - M12+M16	300120	ø12,00 - M12+M16
		200140	ø14,00 - M18	300140	ø14,00 - M18
		200160	ø16,00 - M20	300160	ø16,00 - M20
		200180	ø18,00 - M22+M24	300180	ø18,00 - M22+M24
				300200	ø20,00 - M27+M30
				300220	ø22,00 - M30+M33
				300250	ø25,00 - M33
				300280	ø28,00 - M36

Aufnahmen für Einschraubfräser

Adaptors for end mills with thread shank

Kegelwinkel AT3, Rundlaufgenauigkeit SK zu Werkzeugaufnahme < 0,005
 Taper angle AT3, Concentricity from the taper to the holding part < 0,005

SK40/BT40 G 2,5 - 20.000 U/min. oder U < 1 gmm

Lieferumfang ohne Fräser
 Delivery without tool

Sonderausführungen auf Anfrage
Special executions on inquiry

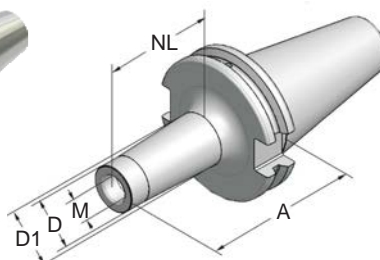

DIN 69871

MAS BT

Art.-Nr.	Typ	M	A	NL	D	D1	Art.-Nr.	Typ	M	A	NL	D	D1
							30.05.08.025	BT30xM 8x25-AD	8	50	25	13	15
							30.05.08.050	BT30xM 8x50-AD	8	75	50	13	23
							30.05.10.025	BT30xM10x25-AD	10	50	25	18	20
							30.05.10.050	BT30xM10x50-AD	10	75	50	18	25
							30.05.12.025	BT30xM12x25-AD	12	50	25	21	24
							30.05.12.050	BT30xM12x50-AD	12	75	50	21	24
							30.05.16.025	BT30xM16x25-AD	16	50	25	29	34
40.01.06.025	SK40xM 6x25-AD+B	6	52	25	9,7	10	40.05.06.025	BT40xM 6x25-AD+B	6	60	25	9,7	10
40.01.06.050	SK40xM 6x50-AD+B	6	77	50	9,7	20	40.05.06.050	BT40xM 6x50-AD+B	6	85	50	9,7	20
40.01.06.075	SK40xM 6x75-AD+B	6	102	75	9,7	23	40.05.06.075	BT40xM 6x75-AD+B	6	110	75	9,7	23
40.01.08.025	SK40xM 8x25-AD+B	8	52	25	13	15	40.05.08.025	BT40xM 8x25-AD+B	8	60	25	13	15
40.01.08.050	SK40xM 8x50-AD+B	8	77	50	13	23	40.05.08.050	BT40xM 8x50-AD+B	8	85	50	13	23
40.01.08.075	SK40xM 8x75-AD+B	8	102	75	13	23	40.05.08.075	BT40xM 8x75-AD+B	8	110	75	13	23
40.01.10.025	SK40xM10x25-AD+B	10	52	25	18	20	40.05.10.025	BT40xM10x25-AD+B	10	60	25	18	20
40.01.10.050	SK40xM10x50-AD+B	10	77	50	18	25	40.05.10.050	BT40xM10x50-AD+B	10	85	50	18	25
40.01.10.075	SK40xM10x75-AD+B	10	102	75	18	28	40.05.10.075	BT40xM10x75-AD+B	10	110	75	18	28
40.01.12.025	SK40xM12x25-AD+B	12	52	25	21	24	40.05.12.025	BT40xM12x25-AD+B	12	60	25	21	24
40.01.12.050	SK40xM12x50-AD+B	12	77	50	21	24	40.05.12.050	BT40xM12x50-AD+B	12	85	50	21	24
40.01.12.075	SK40xM12x75-AD+B	12	102	75	21	31	40.05.12.075	BT40xM12x75-AD+B	12	110	75	21	31
40.01.16.025	SK40xM16x25-AD+B	16	52	25	29	34	40.05.16.025	BT40xM16x25-AD+B	16	60	25	29	34
40.01.16.050	SK40xM16x50-AD+B	16	77	50	29	34	40.05.16.050	BT40xM16x50-AD+B	16	85	50	29	34
40.01.16.075	SK40xM16x75-AD+B	16	102	75	29	34	40.05.16.075	BT40xM16x75-AD+B	16	110	75	29	34

Kegelhülsen MK DIN 228 Form B mit Austreibblappen

Reducing adaptors MT DIN 228 form B with tang

Kegelwinkel AT3, Rundlaufgenauigkeit SK zu Werkzeugaufnahme < 0,005

Taper angle AT3, Concentricity from the taper to the holding part < 0,005

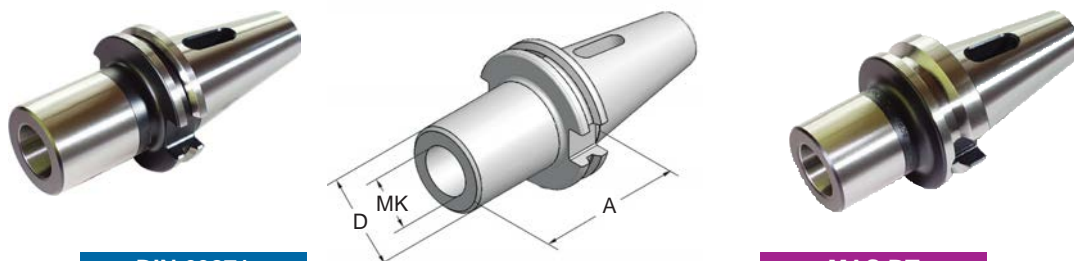

DIN 69871

MAS BT

Art.-Nr.	Typ	A	MK	D	Art.-Nr.	Typ	A	MK	D
30.01.01.5	SK30xMK1x 50-AD	50	1	28	30.05.01.5	BT30xMK1x 50-AD	50	1	25
30.01.02.5	SK30xMK2x 60-AD	60	2	42	30.05.02.5	BT30xMK2x 60-AD	60	2	32
30.01.03.5	SK30xMK3x 80-AD	80	3	50	30.05.03.5	BT30xMK3x 80-AD	80	3	40
40.01.01.5	SK40xMK1x 50-AD	50	1	25	40.05.01.5	BT40xMK1x 50-AD	50	1	25
40.01.02.5	SK40xMK2x 50-AD	50	2	32	40.05.02.5	BT40xMK2x 50-AD	50	2	32
40.01.03.5	SK40xMK3x 70-AD	70	3	40	40.05.03.5	BT40xMK3x 70-AD	70	3	40
40.01.04.5	SK40xMK4x 95-AD	95	4	48	40.05.04.5	BT40xMK4x 95-AD	95	4	48
50.01.01.5	SK50xMK1x 45-AD	45	1	25	50.05.01.5	BT50xMK1x 50-AD	50	1	25
50.01.02.5	SK50xMK2x 60-AD	60	2	32	50.05.02.5	BT50xMK2x 60-AD	60	2	32
50.01.03.5	SK50xMK3x 65-AD	65	3	40	50.05.03.5	BT50xMK3x 65-AD	65	3	40
50.01.04.5	SK50xMK4x 95-AD	95	4	48	50.05.04.5	BT50xMK4x 95-AD	95	4	48
50.01.05.5	SK50xMK5x105-AD	105	5	63	50.05.05.5	BT50xMK5x110-AD	110	5	63

Kegelhülsen MK DIN 228 Form A mit Anzugsgewinde

Reducing adaptors MT DIN 228 form A with retention thread

Kegelwinkel AT3, Rundlaufgenauigkeit SK zu Werkzeugaufnahme < 0,005

Taper angle AT3, Concentricity from the taper to the holding part < 0,005

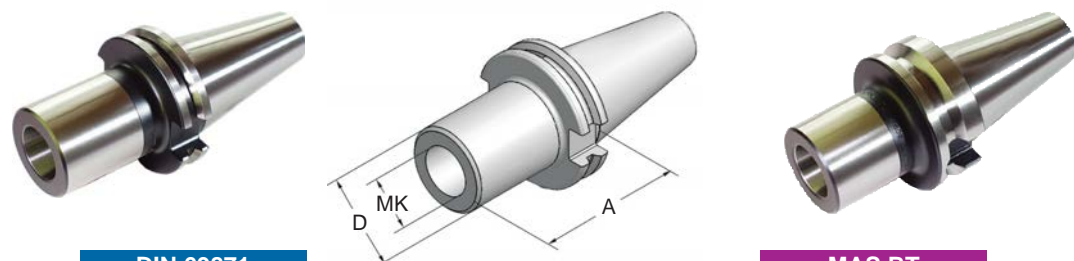

DIN 69871

MAS BT

Art.-Nr.	Typ	A	MK	D	Art.-Nr.	Typ	A	MK	D
40.01.01.55	SK40xMK1x 50	50	1	25	40.05.01.55	BT40xMK1x 50	50	1	25
40.01.02.55	SK40xMK2x 50	50	2	32	40.05.02.55	BT40xMK2x 50	50	2	32
40.01.03.55	SK40xMK3x 70	70	3	40	40.05.03.55	BT40xMK3x 70	70	3	40
40.01.04.55	SK40xMK4x 95	95	4	48	40.05.04.55	BT40xMK4x 95	95	4	48
50.01.02.55	SK50xMK2x 60	60	2	32	50.05.02.55	BT50xMK2x 60	60	2	32
50.01.03.55	SK50xMK3x 65	65	3	40	50.05.03.55	BT50xMK3x 65	65	3	40
50.01.04.55	SK50xMK4x 70	70	4	48	50.05.04.55	BT50xMK4x 70	70	4	48
50.01.05.55	SK50xMK5x100	100	5	63	50.05.05.55	BT50xMK5x100	100	5	63

Stellhülseaufnahmen nach DIN 6327

Adaptors for setting sleeves to DIN 6327

Kegelwinkel AT3, Rundlaufgenauigkeit SK zu Werkzeugaufnahme < 0,005
Taper angle AT3, Concentricity from the taper to the holding part < 0,005

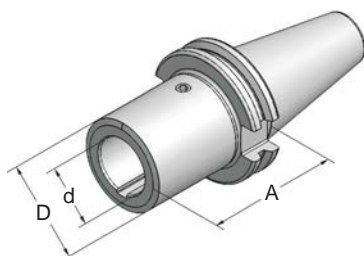

DIN 69871

MAS BT

Art.-Nr.	Typ	A	d	D	Art.-Nr.	Typ	A	d	D
40.01.28.7	SK40x28x 70-AD	70	28	41	40.05.28.7	BT40x28x 70-AD	70	28	41
40.01.36.7	SK40x36x120-AD	120	36	50	40.05.36.7	BT40x36x120-AD	120	36	50
50.01.28.7	SK50x28x100-AD	100	28	50	50.05.28.7	BT50x28x100-AD	100	28	50
50.01.36.7	SK50x36x100-AD	100	36	60	50.05.36.7	BT50x36x100-AD	100	36	60
50.01.48.7	SK50x48x100-AD	100	48	80	50.05.48.7	BT50x48x100-AD	100	48	80

Adapter Adaptors

SK DIN 69871 – HSK DIN 69893

MAS BT – HSK DIN 69893

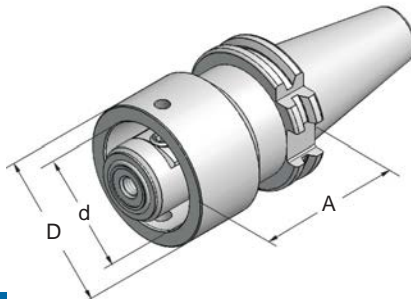

DIN 69871

MAS BT

Art.-Nr.	Typ	SK	HSK	A	D	Art.-Nr.	Typ	BT	HSK	A	D
40.01.50A	SK40xHSK-A50-AD+B	40	A50	50	50	40.05.40A	BT40xHSK-A40-AD+B	40	A40	50	40
40.01.50E	SK40xHSK-E50-AD+B	40	E50	50	50	40.05.50A	BT40xHSK-A50-AD+B	40	A50	50	50
40.01.63A	SK40xHSK-A63-AD+B	40	A63	75	63	40.05.63A	BT40xHSK-A63-AD+B	40	A63	75	63
40.01.63E	SK40xHSK-E63-AD+B	40	E63	75	63						
50.01.50A	SK50xHSK-A50-AD+B	50	A50	50	50						
50.01.50E	SK50xHSK-E50-AD+B	50	E50	50	50						
50.01.63A	SK50xHSK-A63-AD+B	50	A63	50	63						

Einstelldorn in Holzetui

Control arbor in wooden case

Zum Einstellen des absoluten Nullpunktes
und der Parallelitäts-Korrektur

inkl. Prüfprotokoll
incl. Certificate

*Sondergrößen auf Anfrage!
Special size on inquiry!*

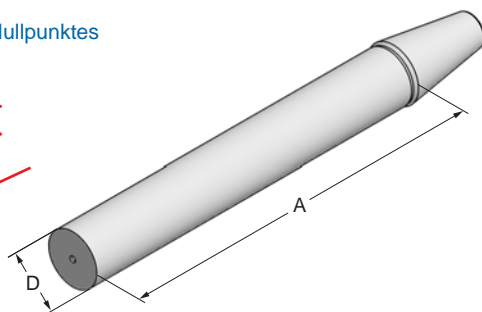

**DIN 69871
MAS BT**

Art.-Nr.	Typ	A	D
30.05.200	SK30xø30x200	200	30
40.05.315	SK40xø30x315	315	30
50.05.315	SK50xø50x315	315	50

Einstelldorn mit Mitnehmernuten in Holzetui

Control arbor with groove in wooden case

Zum Einstellen des absoluten Nullpunktes
und der Parallelitäts-Korrektur

inkl. Prüfprotokoll
incl. Certificate

*Sondergrößen auf Anfrage!
Special size on inquiry!*

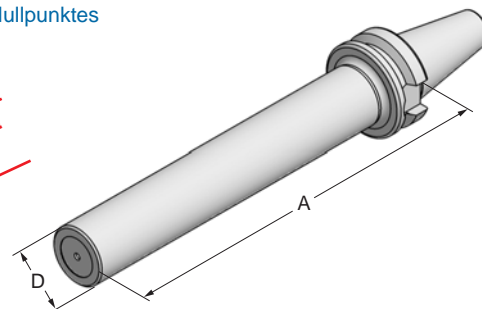

MAS BT

Art.-Nr.	Typ	A	D
30.05.200-2	BT30xø30x200	200	30

Rohlinge

Blanks



*Sondergrößen auf Anfrage!
Special size on inquiry!*

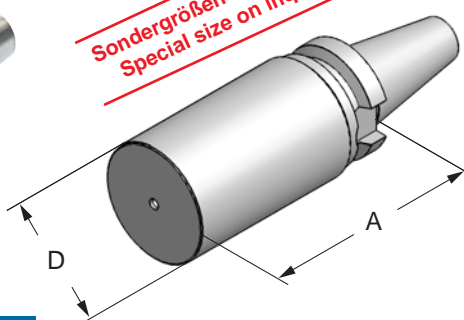

DIN 69871

MAS BT

Art.-Nr.	Typ	A	D	Art.-Nr.	Typ	A	D
30.01.150.15	SK30xø54x150	150	54	30.05.200.15	BT30xø49x200	200	49
40.01.250.15	SK40xø64x250	250	64	40.05.250.15	BT40xø64x250	250	64

DIN 2080

Art.-Nr. 40.00. ...

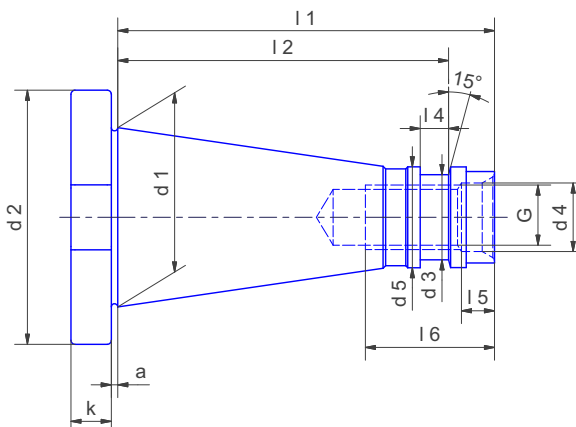
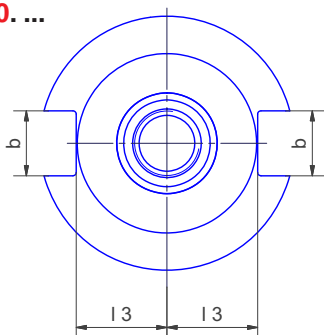

SK	d 1	d 2	d 3	d 4	d 5	G	a	b	l 1	l 2	l 3	l 4	l 5	l 6	k
30	31,75	50,0	16,5	13	17,10	M 12	1,6	16,1	68,4	51,4	16,2	3	5,5	24	8
40	44,45	63,0	21,1	17	25,00	M 16	1,6	16,1	93,4	82,0	22,5	7	8,2	32	10
50	69,85	97,5	32,0	26	39,29	M 24	3,2	25,7	126,8	115,0	35,3	13	11,5	47	12

Spannzangenfutter für Spannzangen ER/ESX DIN 6499 / ISO 15488

Collet chucks for collets ER/ESX DIN 6499 / ISO 15488

Kegelwinkel AT3, Rundlaufgenauigkeit Steilkegel zu Werkzeugaufnahme < 0,005
Taper angle AT3, Concentricity from the taper to the holding part < 0,005

Spannzangen siehe Seiten 48+49
Collets see pages 48+49

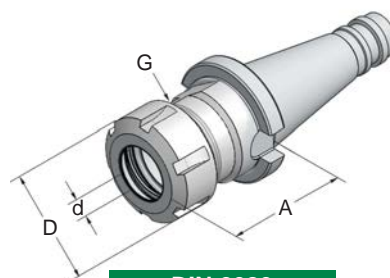

DIN 2080

DIN 2080

Art.-Nr.	Typ	A	d	D	G	Art.-Nr.	Typ	A	d	D	G
30.00.16.2	ISO30xER25x50	50	1-16	42	M14x0,75	50.00.20.2	ISO50xER32x50	50	2-20	50	M22x1,50
30.00.20.2	ISO30xER32x50	50	2-20	50	M22x1,50	50.00.26.2	ISO50xER40x50	50	3-30	63	M32x1,50
40.00.16.2	ISO40xER25x50	50	1-16	42	M14x0,75	50.00.34.2	ISO50xER50x60	60	6-34	78	M40x1,50
40.00.20.2	ISO40xER32x50	50	2-20	50	M22x1,50						
40.00.26.2	ISO40xER40x50	50	3-30	63	M32x1,50						

Spannzangenfutter DIN 6391 für Spannzangen DIN 6388 / ISO 10897

Collet chucks DIN 6391 for collets DIN 6388 / ISO 10897

Kegelwinkel AT3, Rundlaufgenauigkeit Steilkegel zu Werkzeugaufnahme < 0,005
Taper angle AT3, Concentricity from the taper to the holding part < 0,005

Spannzangen auf Anfrage
Collets on inquiry

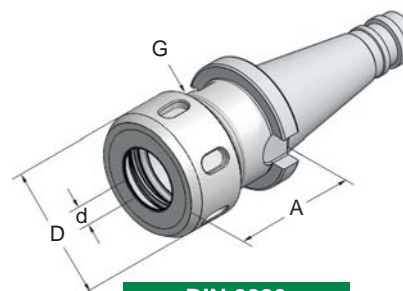

DIN 2080

DIN 2080

Art.-Nr.	Typ	A	d	D	G	Art.-Nr.	Typ	A	d	D	G
40.00.25.1	ISO40xOZ25x63	63	2-25	60	M48x2,0	50.00.25.1	ISO50xOZ25x63	63	2-25	60	M48x2,0
						50.00.32.1	ISO50xOZ32x70	70	4-32	72	M60x2,5

Kombi-Aufsteckfräsdorne DIN 6358

Universal arbors DIN 6358

Kegelwinkel AT3, Rundlaufgenauigkeit Steilkegel zu Werkzeugaufnahme < 0,005
Taper angle AT3, Concentricity from the taper to the holding part < 0,005



DIN 2080

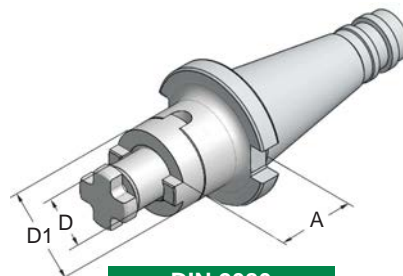

DIN 2080

Art.-Nr.	Typ	A	D	D1	Art.-Nr.	Typ	A	D	D1
30.00.16.4	ISO30x16x40	40	16	32	50.00.16.4	ISO50x16x52	52	16	32
30.00.22.4	ISO30x22x40	40	22	40	50.00.22.4	ISO50x22x52	52	22	40
30.00.27.4	ISO30x27x40	40	27	48	50.00.27.4	ISO50x27x52	52	27	48
40.00.16.4	ISO40x16x52	52	16	32	50.00.32.4	ISO50x32x52	52	32	58
40.00.22.4	ISO40x22x52	52	22	40	50.00.40.4	ISO50x40x52	52	40	70
40.00.27.4	ISO40x27x52	52	27	48	50.00.50.4	ISO50x50x52	52	50	90
40.00.32.4	ISO40x32x52	52	32	58					
40.00.40.4	ISO40x40x52	52	40	70					

Messerkopfaufnahmen DIN 6357

Shell mill adaptors for facing cutters DIN 6357

Kegelwinkel AT3, Rundlaufgenauigkeit Steilkegel zu Werkzeugaufnahme < 0,005
Taper angle AT3, Concentricity from the taper to the holding part < 0,005



DIN 2080

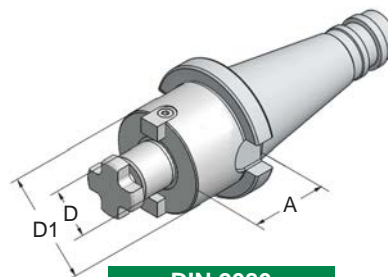

DIN 2080

Art.-Nr.	Typ	A	D	D1	Art.-Nr.	Typ	A	D	D1
40.00.16.9	ISO40x16x30	30	16	39	50.00.22.9	ISO50x22x35	35	22	49
40.00.22.9	ISO40x22x30	30	22	49	50.00.27.9	ISO50x27x35	35	27	60
40.00.27.9	ISO40x27x30	30	27	60	50.00.32.9	ISO50x32x40	40	32	68
40.00.32.9	ISO40x32x30	30	32	68	50.00.40.9	ISO50x40x40	40	40	88
					50.00.60.9	ISO50x60x55	70	55	128

Zylinderschaftaufnahmen Weldon DIN 1835 B

Holder for straight shank tools Weldon DIN 1835 B

Kegelwinkel AT3, Rundlaufgenauigkeit Steilkegel zu Werkzeugaufnahme < 0,005
 Taper angle AT3, Concentricity from the taper to the holding part < 0,005

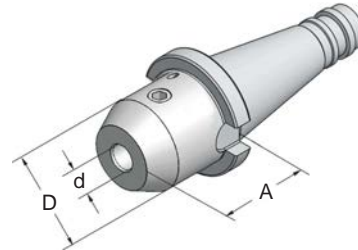

DIN 2080

DIN 2080

Art.-Nr.	Typ	A	d	D	Art.-Nr.	Typ	A	d	D
30.00.06.6	ISO30x06x50	50	6	25	50.00.06.6	ISO50x06x63	63	6	25
30.00.08.6	ISO30x08x50	50	8	28	50.00.08.6	ISO50x08x63	63	8	28
30.00.10.6	ISO30x10x50	50	10	35	50.00.10.6	ISO50x10x63	63	10	35
30.00.12.6	ISO30x12x50	50	12	42	50.00.12.6	ISO50x12x63	63	12	42
30.00.16.6	ISO30x16x50	50	16	48	50.00.14.6	ISO50x14x63	63	14	44
30.00.20.6	ISO30x20x50	50	20	50	50.00.16.6	ISO50x16x63	63	16	48
					50.00.18.6	ISO50x18x63	63	18	50
40.00.06.6	ISO40x06x50	50	6	25	50.00.20.6	ISO50x20x63	63	20	52
40.00.08.6	ISO40x08x50	50	8	28	50.00.25.6	ISO50x25x80	80	25	64
40.00.10.6	ISO40x10x50	50	10	35	50.00.32.6	ISO50x32x80	80	32	72
40.00.12.6	ISO40x12x50	50	12	42	50.00.40.6	ISO50x40x90	90	40	80
40.00.14.6	ISO40x14x50	50	14	44					
40.00.16.6	ISO40x16x63	63	16	48					
40.00.18.6	ISO40x18x63	63	18	50					
40.00.20.6	ISO40x20x63	63	20	50					
40.00.25.6	ISO40x25x80	80	25	64					
40.00.32.6	ISO40x32x80	80	32	72					

NC-Bohrfutter für Rechts- und Linkslauf

CNC-Drill chucks for clockwise and anti-clockwise rotation

Kegelwinkel AT3, Rundlaufgenauigkeit Steilkegel zu Werkzeugaufnahme < 0,04
Taper angle AT3, Concentricity from the taper to the holding part < 0,04

Grundkörper gewuchtet G 2,5 - 8.000 U/min.
Base-body balanced G 2,5 - 8.000 r.p.m



DIN 2080

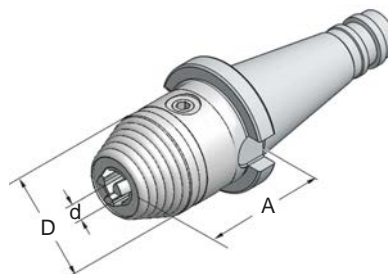

DIN 2080

Art.-Nr.	Typ	A	d	D	Art.-Nr.	Typ	A	d	D
40.00.13	ISO40x1-13x84	84	1-13	50	50.00.13	ISO50x1-13x94	94	1-13	50
40.00.16	ISO40x3-16x84	84	3-16	57	50.00.16	ISO50x3-16x94	97	3-16	57

Bohrfutteraufnahmen DIN 238

Drill chuck arbors DIN 238

Kegelwinkel AT3, Rundlaufgenauigkeit Steilkegel zu Werkzeugaufnahme < 0,005
Taper angle AT3, Concentricity from the taper to the holding part < 0,005

Bohrfutter

Drill chuck

*Das Bohrfutter muss separat bestellt werden !
The drill chuck has to be ordered separately !*



DIN 2080

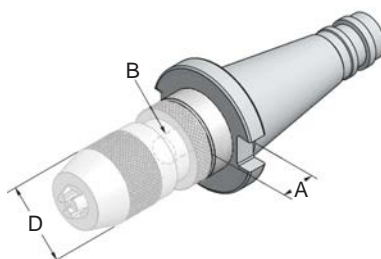

Bohrfutter

Art.-Nr.	Typ	A	B	D	Art.-Nr.	Typ
30.00.12.8	ISO30xB12	15	12	43	287100	B12xø0,5-10x80
30.00.16.8	ISO30xB16	17	16	50	289100	B16xø1,0-13x90
					290100	B16xø2,5-16x95
40.00.12.8	ISO40xB12	15	12	43		
40.00.16.8	ISO40xB16	17	16	50		
50.00.16.8	ISO50xB12	20	16	50		
50.00.18.8	ISO50xB16	20	18	56		

Gewindeschneidfutter für Spannzangen ER/ESX

Tapping heads for collets ER/ESX

Spannzangen siehe Seiten 48+49
Collets see pages 48+49

Längenausgleich auf Druck + Zug

Flexible position for compression and tension

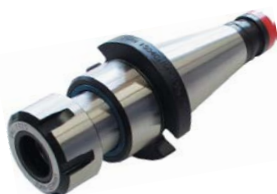

DIN 2080



ER 16

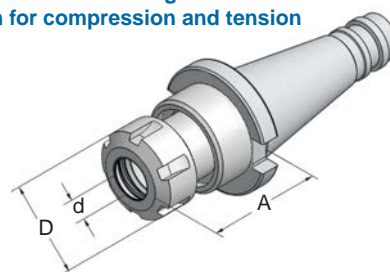

DIN 2080

Art.-Nr.	Typ	A	d	D	Art.-Nr.	Typ	A	d	D
40.00.12.13	ISO40xER16x55	55	1-10 für M2-M12	28	50.00.20.13	ISO50xER25x90	90	2-16 für M4-M20	50
40.00.20.13	ISO40xER25x74	74	2-16 für M4-M20	42	50.00.33.13	ISO50xER40x90	90	4-30 für M8-M33	63
40.00.24.13	ISO40xER32x94	94	3-20 für M6-M24	50					

Kegelhülsen MK DIN 228 Form B mit Austreiblappen

Reducing adaptors MT DIN 228 form B with tang

Kegelwinkel AT3, Rundlaufgenauigkeit Steilkegel zu Werkzeugaufnahme < 0,005
Taper angle AT3, Concentricity from the taper to the holding part < 0,005



DIN 2080

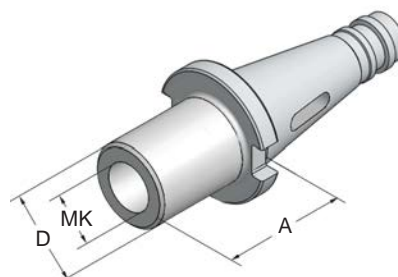

DIN 2080

Art.-Nr.	Typ	A	MK	D	Art.-Nr.	Typ	A	MK	D
40.00.01.5	ISO40xMK1x50	50	1	25	50.00.01.5	ISO50xMK1x 45	45	1	25
40.00.02.5	ISO40xMK2x50	50	2	32	50.00.02.5	ISO50xMK2x 60	60	2	32
40.00.03.5	ISO40xMK3x65	65	3	40	50.00.03.5	ISO50xMK3x 65	65	3	40
40.00.04.5	ISO40xMK4x95	95	4	48	50.00.04.5	ISO50xMK4x 70	70	4	48
					50.00.05.5	ISO50xMK5x105	105	5	63

Kegelhülsen MK DIN 228 Form A mit Anzugsgewinde

Reducing adaptors MT DIN 228 form A with retention thread

Kegelwinkel AT3, Rundlaufgenauigkeit Steilkegel zu Werkzeugaufnahme < 0,005
Taper angle AT3, Concentricity from the taper to the holding part < 0,005



DIN 2080

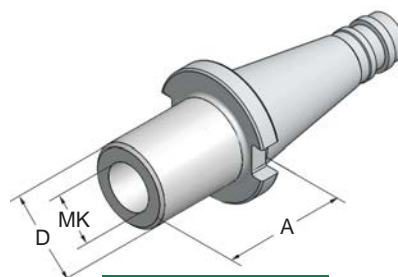

DIN 2080

Art.-Nr.	Typ	A	MK	D	Art.-Nr.	Typ	A	MK	D
40.00.01.55	ISO40xMK1x50	50	1	25	50.00.02.55	ISO50xMK2x 60	60	2	32
40.00.02.55	ISO40xMK2x50	50	2	32	50.00.03.55	ISO50xMK3x 65	65	3	40
40.00.03.55	ISO40xMK3x65	65	3	40	50.00.04.55	ISO50xMK4x 65	65	4	48
40.00.04.55	ISO40xMK4x95	95	4	48	50.00.05.55	ISO50xMK5x120	120	5	63

Werkzeugaufnahmen zur Kühlmittel- bzw. Luftzufuhr

Toolholders for coolant- and air supply

Kegelwinkel AT3, Rundlaufgenauigkeit Steilkegel zu Werkzeugaufnahme < 0,005
Taper angle AT3, Concentricity from the taper to the holding part < 0,005

max. U/min / max. r.p.m.: 3000
Kühlmitteldruck / Coolant pressure: max. 6 bar
Luftdruck / Air pressure: max. 4 bar



DIN 2080

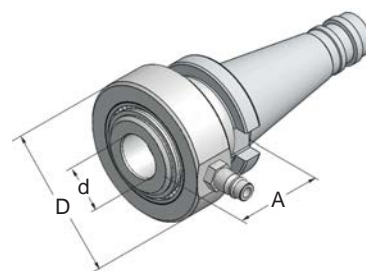

DIN 2080

Art.-Nr.	Typ	A	d	D	Art.-Nr.	Typ	A	d	D
40.00.25.68	ISO40	50	25	80	50.00.25.68	ISO50	50	25	80
40.00.32.68	ISO40	50	32	80	50.00.32.68	ISO50	50	32	80

Anzugsbolzen DIN 2080
Retention knobs DIN 2080

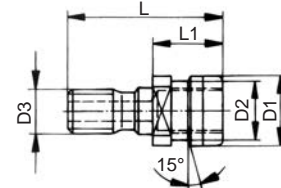

Art.-Nr.	Typ	D1	D2	D3	L	L1	Art.-Nr.	Typ	D1	D2	D3	L	L1
40.16.14	DIN 2080	25,3	21,0	M16	53	25,1	50.24.14	DIN 2080	39,6	32,0	M24	65	25,1
40.16.142	DIN 2080-MK2	25,3	21,0	M10	100	25,1	50.24.142	DIN 2080-MK2	39,6	32,0	M10	145	25,1
40.16.143	DIN 2080-MK3	25,3	21,0	M12	103	25,1	50.24.143	DIN 2080-MK3	39,6	32,0	M12	135	25,1
40.16.144	DIN 2080-MK4	25,3	21,0	M16	115	25,1	50.24.144	DIN 2080-MK4	39,6	32,0	M16	135	25,1
							50.24.145	DIN 2080-MK5	39,6	32,0	M20	135	25,1

Anzugsbolzen DIN 69872
Retention knobs DIN 69872

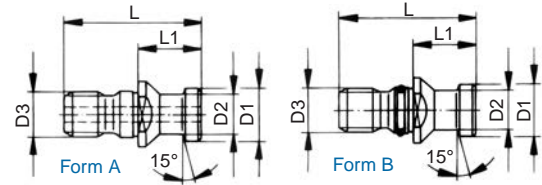

Art.-Nr.	Typ	D1	D2	D3	L	L1	Art.-Nr.	Typ	D1	D2	D3	L	L1
30.12.1	DIN 69872-A	13,0	9,0	M12	44	24	30.12.102	DIN 69872-MK2	13,0	9,0	M10	90	24
40.16.1	DIN 69872-A	19,0	14,0	M16	54	26	30.12.103	DIN 69872-MK3	13,0	9,0	M12	95	24
50.24.1	DIN 69872-A	28,0	21,0	M24	74	34	40.16.102	DIN 69872-MK2	19,0	14,0	M10	101	26
30.12.11	DIN 69872-B	13,0	9,0	M12	44	24	40.16.103	DIN 69872-MK3	19,0	14,0	M12	104	26
40.16.11	DIN 69872-B	19,0	14,0	M16	54	26	40.16.104	DIN 69872-MK4	19,0	14,0	M16	116	26
50.24.11	DIN 69872-B	28,0	21,0	M24	74	34	50.24.102	DIN 69872-MK2	28,0	21,0	M10	154	34
							50.24.103	DIN 69872-MK3	28,0	21,0	M12	144	34
40.16.15	DIN 69872-A	19,0	14,0	M16	54	29	50.24.104	DIN 69872-MK4	28,0	21,0	M16	144	34
							50.24.105	DIN 69872-MK5	28,0	21,0	M20	144	34

Anzugsbolzen ISO 7388
Retention knobs ISO 7388

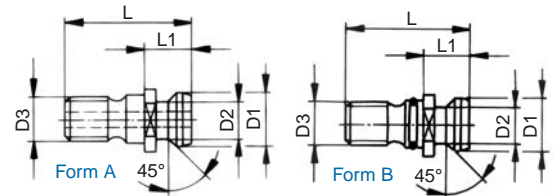

Art.-Nr.	Typ	D1	D2	D3	L	L1	Art.-Nr.	Typ	D1	D2	D3	L	L1
40.16.12	ISO 7388-A	18,9	12,9	M16	44,5	16,4	40.16.122	ISO 7388-MK2	18,9	12,9	M10	91	16,4
50.24.12	ISO 7388-A	29,1	19,6	M24	65,5	25,5	40.16.123	ISO 7388-MK3	18,9	12,9	M12	94	16,4
							40.16.124	ISO 7388-MK4	18,9	12,9	M16	104	16,4
40.16.13	ISO 7388-B	18,9	12,9	M16	44,5	16,4	50.24.122	ISO 7388-MK2	29,1	19,6	M10	145	25,5
50.24.13	ISO 7388-B	29,1	19,6	M24	65,5	25,5	50.24.123	ISO 7388-MK3	29,1	19,6	M12	135	25,5
							50.24.124	ISO 7388-MK4	29,1	19,6	M16	135	25,5
							50.24.125	ISO 7388-MK5	29,1	19,6	M20	135	25,5

Anzugsbolzen MAS BT45°/60°/90°
Retention knobs MAS BT45°/60°/90°

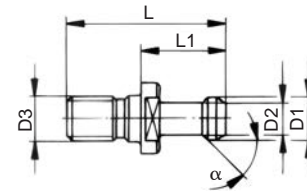

Art.-Nr.	Typ	D1	D2	D3	L	L1	Art.-Nr.	Typ	D1	D2	D3	L	L1
30.12.4	BT30x45°	11,0	7,0	M12	43	23	40.16.402	BT40x45°-MK2	15,0	10,0	M10	110	35
30.12.41	BT30x60°	11,0	7,0	M12	43	23	40.16.403	BT40x45°-MK3	15,0	10,0	M12	113	35
40.16.4	BT40x45°	15,0	10,0	M16	60	35	40.16.404	BT40x45°-MK4	15,0	10,0	M16	125	35
40.16.41	BT40x60°	15,0	10,0	M16	60	35	40.16.412	BT40x60°-MK2	15,0	10,0	M10	110	35
40.16.42	BT40x90°	15,0	10,0	M16	60	35	40.16.413	BT40x60°-MK3	15,0	10,0	M12	113	35
50.24.4	BT50x45°	23,0	17,0	M24	85	45	40.16.414	BT40x60°-MK4	15,0	10,0	M16	125	35
50.24.41	BT50x60°	23,0	17,0	M24	85	45	50.24.402	BT50x45°-MK2	23,0	17,0	M10	165	45
50.24.42	BT50x90°	23,0	17,0	M24	85	45	50.24.403	BT50x45°-MK3	23,0	17,0	M12	155	45
40.16.4-C	BT40x45° i.K.	15,0	10,0	M16	60	35	50.24.404	BT50x45°-MK4	23,0	17,0	M16	155	45
50.24.4-C	BT50x45° i.K.	23,0	17,0	M24	85	45	50.24.405	BT50x45°-MK5	23,0	17,0	M20	155	45

Spannmuttern DIN 6499

Clamping nuts DIN 6499



Art.-Nr. 711120 - SW17
Art.-Nr. 716120 - SW25
Spannschlüssel Typ EP

Art.-Nr. 720120 - 750120
Spannschlüssel Typ E

Spannmuttern DIN 6499 gleitgelagert

Clamping nuts DIN 6499 friction bearing

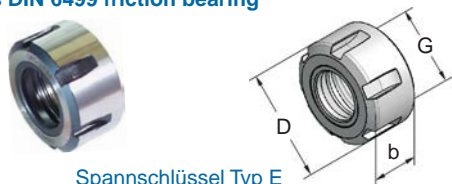

Spannschlüssel Typ E

Spannschlüssel

Key

Typ EP



Typ E



Art.-Nr.	Typ	D	b	G	Nm max.
711120	UMQ / ER11	19	12	M14x0,75	30
716120	UMQ / ER16	28	18	M22x1,50	70
720120	UMQ / ER20	34	19,5	M25x1,50	100
725120	UMQ / ER25	42	20,5	M32x1,50	130
732120	UMQ / ER32	50	23	M40x1,50	170
740120	UMQ / ER40	63	26	M50x1,50	220
750120	UMQ / ER50	78	35	M64x2,00	300

Art.-Nr.	Typ	D	b	G	Nm max.
716123	GMG / ER16	32	18	M22x1,50	70
720123	GMG / ER20	35	20	M25x1,50	100
725123	GMG / ER25	42	20,5	M32x1,50	130
732123	GMG / ER32	50	23	M40x1,50	170
740123	GMG / ER40	63	26	M50x1,50	220

Art.-Nr.	Typ	für Spannmutter	SW
911180	E 11 P	711120	17
916180	E 16 P	716120	25
920180	E 20 P		30
916181	E 16	716123, 716124, 716130	
920181	E 20	720120, 720123, 720124, 720130	
925180	E 25	725120, 725123, 725124, 725130	
932180	E 32	732120, 732123, 732124, 732130	
940180	E 40	740120, 740123, 740124, 740130	
950180	E 50	750120	

Spannmuttern DIN 6499 mini

Clamping nuts DIN 6499 mini

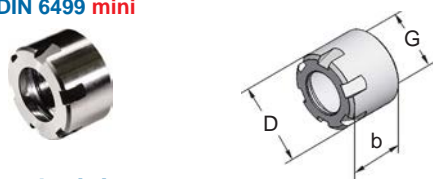

Spannschlüssel mini

Key mini



Art.-Nr.	Typ	D	b	G	Nm max.
908100	ER 8M	12	11	M10x0,75	6
911100	ER11M	16	12	M13x0,75	20
916100	ER16M	22	18	M19x1,00	30
920100	ER20M	28	19,5	M24x1,00	35
925100	ER25M	35	20,5	M30x1,00	40

Art.-Nr.	Typ	für Spannmutter
908160	E 8 mini	908100
911160	E 11 mini	911100
916160	E 16 mini	916100
920160	E 20 mini	920100
925160	E 25 mini	925100







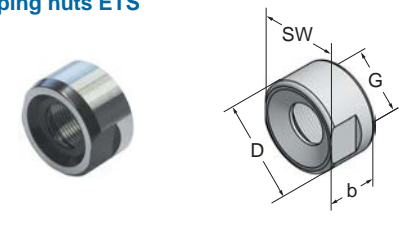

Spannmuttern DIN 6499 mini

Clamping nuts DIN 6499 mini

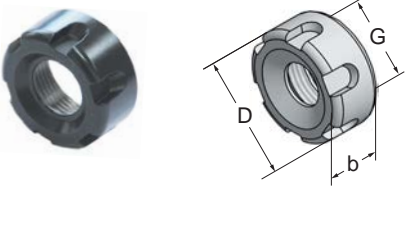

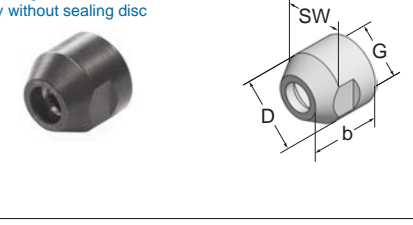
Art.-Nr.	Typ	D	b	G	SW	Nm max.
716120-2	ER16	25	17,5	M20x1,00	22	30
916162	Spannschlüssel ER16				22	

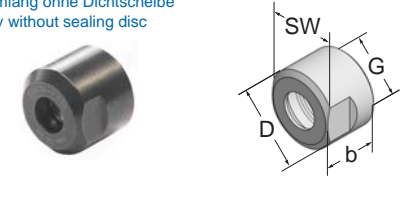

Spannmuttern ETS Clamping nuts ETS 	Art.-Nr. Typ D b G SW Nm max. 712130 ETS12 19 12 M14x0,75 17 10 716120-2ETS ETS16 27 15 M20x1,00 24 30
	912163 Spanschlüssel ETS12 17 916163 Spanschlüssel ETS16 24 
	Art.-Nr. Typ D b G Spanschlüssel Nm max. 716130 ETS16 32 15 M22x1,50 916181 30 720130 ETS20 35 16,5 M25x1,50 920181 30 725130 ETS25 42 18,5 M32x1,50 925180 120 732130 ETS32 50 22 M40x1,50 932180 150 740130 ETS40 63 25 M50x1,50 940180 200
	Spanschlüssel Typ E siehe Seite 44 Key Type E see page 44
Spannmuttern DIN 6499 gleitgelagert für Dichtscheiben Clamping nuts DIN 6499 friction bearing for sealing discs <small>Lieferumfang ohne Dichtscheibe Delivery without sealing disc</small> 	Art.-Nr. Typ D b G Nm max. Dichtscheibe 716124 GMGC / ER16 28 22,5 M22x1,5 70 excl. DS / ER16 720124 GMGC / ER20 34 24,5 M25x1,5 100 excl. DS / ER20 725124 GMGC / ER25 42 25 M32x1,5 130 excl. DS / ER25 732124 GMGC / ER32 50 27,5 M40x1,5 170 excl. DS / ER32 740124 GMGC / ER40 63 30,5 M50x1,5 220 excl. DS / ER40
	Spanschlüssel Typ E siehe Seite 44 Key Type E see page 44
Spannmuttern DIN 6499 mini für Dichtscheiben Clamping nuts DIN 6499 for sealing discs <small>Lieferumfang ohne Dichtscheibe Delivery without sealing disc</small> 	Art.-Nr. Typ D b G SW Nm max. 716124-2 ER16C mini 25 22 M20x1,0 22 30 excl. Dichtscheibe/Sealing disc DS / ER16
	916162 Spanschlüssel ER16 22 
Spannmuttern ETS mini für Dichtscheiben Clamping nuts ETS mini for sealing discs <small>Lieferumfang ohne Dichtscheibe Delivery without sealing disc</small> 	Art.-Nr. Typ D b G SW Nm max. 716124-2ETS ETS16C 27 22,5 M20x1,00 24 30 excl. Dichtscheibe/Sealing disc DS / ER16
	916163 Spanschlüssel ETS16 24 

Spannmuttern DIN 6499 / DIN 6388 zum Auswuchten

incl. 2 Wuchtgewichten Art.- Nr. 600101

Clamping nuts DIN 6499 / DIN 6388 for balancing

incl. 2 balancing weights Art.- Nr. 600101

Lieferumfang ohne Spannzange und Werkzeug
Delivery without collet and tool

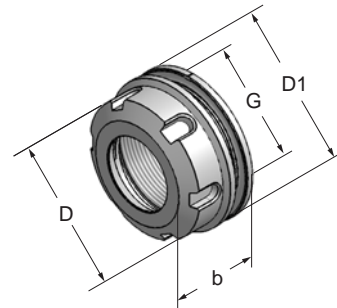

Art.-Nr.	Typ	D	D1	b	G	Nm max.
725120-B	ER25	42	46	24	M32x1,5	130
732120-B	ER32	50	54	25	M40x1,5	170
740120-B	ER40	63	64	27	M50x1,5	220
825120-B	OZ25	63	63	30	M48x2,0	200

Wischer für SK
Cone cleaners SK



Wischer für MK
Cone cleaners MK



Art.-Nr.	Typ
284100	SK 30
285100	SK 40
286100	SK 50

Art.-Nr.	Typ
341100	MK 2
342100	MK 3
343100	MK 4
344100	MK 5

Fräseranzugschrauben DIN 6367
Drawn-in bolts DIN 6367



Schlüssel DIN 6368
Keys DIN 6368



Spannschrauben Weldon
Clamping screws Weldon



Art.-Nr.	Typ	Spann-ø
163100	M 8	ø16
164100	M10	ø22
165100	M12	ø27
166100	M16	ø32
167100	M20	ø40
168100	M24	ø50

Art.-Nr.	Spann-ø
170101	ø16
171101	ø22
172101	ø27
173101	ø32
174101	ø40

Art.-Nr.	Typ	Weldon-ø
147100	M 6x10	ø6
148100	M 8x10	ø8
149100	M10x12	ø10
150100	M12x16	ø12, ø14
151100	M14x16	ø16, ø18
152100	M16x16	ø20
153100	M18x2x20	ø25
154100	M20x2x20	ø32, ø40
329100	M24x2x25	ø50, ø60

**Dichtscheiben für Spannmuttern DIN 6499, DIN 6388 + ETS
für Werkzeuge mit interner Kühlmittelzufuhr**
Sealing discs for clamping nuts DIN 6499, DIN 6388 + ETS
for tools with internal coolant supply

Kühlmitteldruck / Coolant pressure min. 5 bar - max. 100 bar

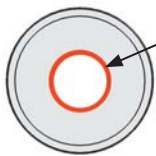

Der eingelegte O-Ring gewährleistet interne Kühlmittelzufuhr durch das gespannte Werkzeug direkt zur Werkzeugschneide

The inserted O-ring seal ensures a coolant supply internally through the clamped tool directly to the cutting edge

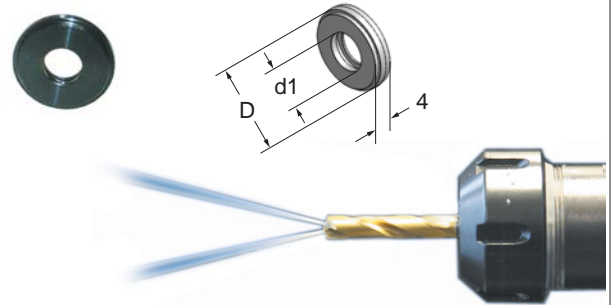

**Dichtscheiben für Spannmuttern
Ortlieb DIN 6388
für Werkzeuge mit interner
Kühlmittelzufuhr**

Sealing discs for clamping nuts
Ortlieb DIN 6388
for tools with internal coolant supply

Art.-Nr. Typ D d1

Art.-Nr.	Typ	D	d1	Art.-Nr.	Typ	D	d1	Art.-Nr.	Typ	D	d1
316040	DS/ER16	13	ø4 - 3	332040	DS/ER32	27	ø4 - 3	350050	DS/OZ25	31	ø5 - 4
316050	DS/ER16	13	ø5 - 4	332050	DS/ER32	27	ø5 - 4	350060	DS/OZ25	31	ø6 - 5
316060	DS/ER16	13	ø6 - 5	332060	DS/ER32	27	ø6 - 5	350070	DS/OZ25	31	ø7 - 6
316070	DS/ER16	13	ø7 - 6	332070	DS/ER32	27	ø7 - 6	350080	DS/OZ25	31	ø8 - 7
316080	DS/ER16	13	ø8 - 7	332080	DS/ER32	27	ø8 - 7	350090	DS/OZ25	31	ø9 - 8
316090	DS/ER16	13	ø9 - 8	332090	DS/ER32	27	ø9 - 8	350100	DS/OZ25	31	ø10 - 9
316100	DS/ER16	13	ø10 - 9	332100	DS/ER32	27	ø10 - 9	350110	DS/OZ25	31	ø11 - 10
				332110	DS/ER32	27	ø11-10	350120	DS/OZ25	31	ø12-11
320040	DS/ER20	16	ø4 - 3	332120	DS/ER32	27	ø12-11	350130	DS/OZ25	31	ø13-12
320050	DS/ER20	16	ø5 - 4	332130	DS/ER32	27	ø13-12	350140	DS/OZ25	31	ø14-13
320060	DS/ER20	16	ø6 - 5	332140	DS/ER32	27	ø14-13	350150	DS/OZ25	31	ø15-14
320070	DS/ER20	16	ø7 - 6	332150	DS/ER32	27	ø15-14	350160	DS/OZ25	31	ø16-15
320080	DS/ER20	16	ø8 - 7	332160	DS/ER32	27	ø16-15	350170	DS/OZ25	31	ø17-16
320090	DS/ER20	16	ø9 - 8	332170	DS/ER32	27	ø17-16	350180	DS/OZ25	31	ø18-17
320100	DS/ER20	16	ø10 - 9	332180	DS/ER32	27	ø18-17	350190	DS/OZ25	31	ø19-18
320110	DS/ER20	16	ø11-10	332190	DS/ER32	27	ø19-18	350200	DS/OZ25	31	ø20-19
320120	DS/ER20	16	ø12-11	332200	DS/ER32	27	ø20-19	350210	DS/OZ25	31	ø21-20
320130	DS/ER20	16	ø13-12					350220	DS/OZ25	31	ø22-21
				340050	DS/ER40	33,5	ø5 - 4	350230	DS/OZ25	31	ø23-22
325040	DS/ER25	21	ø4 - 3	340060	DS/ER40	33,5	ø6 - 5	350240	DS/OZ25	31	ø24-23
325050	DS/ER25	21	ø5 - 4	340070	DS/ER40	33,5	ø7 - 6	350250	DS/OZ25	31	ø25-24
325060	DS/ER25	21	ø6 - 5	340080	DS/ER40	33,5	ø8 - 7				
325070	DS/ER25	21	ø7 - 6	340090	DS/ER40	33,5	ø9 - 8				
325080	DS/ER25	21	ø8 - 7	340100	DS/ER40	33,5	ø10 - 9				
325090	DS/ER25	21	ø9 - 8	340110	DS/ER40	33,5	ø11-10				
325100	DS/ER25	21	ø10 - 9	340120	DS/ER40	33,5	ø12-11				
325110	DS/ER25	21	ø11-10	340130	DS/ER40	33,5	ø13-12				
325120	DS/ER25	21	ø12-11	340140	DS/ER40	33,5	ø14-13				
325130	DS/ER25	21	ø13-12	340150	DS/ER40	33,5	ø15-14				
325140	DS/ER25	21	ø14-13	340160	DS/ER40	33,5	ø16-15				
325150	DS/ER25	21	ø15-14	340170	DS/ER40	33,5	ø17-16				
325160	DS/ER25	21	ø16-15	340180	DS/ER40	33,5	ø18-17				
				340190	DS/ER40	33,5	ø19-18				
				340200	DS/ER40	33,5	ø20-19				
				340210	DS/ER40	33,5	ø21-20				
				340220	DS/ER40	33,5	ø22-21				
				340230	DS/ER40	33,5	ø23-22				
				340240	DS/ER40	33,5	ø24-23				
				340250	DS/ER40	33,5	ø25-24				
				340260	DS/ER40	33,5	ø26-25				

Spannzangen ER/ESX DIN 6499-B rego-fix

Collets type ER/ESX DIN 6499-B rego-fix

Sätze / Sets 111002, 116002, 120002, 125002, 132002, 140002
nicht Original rego-fix / not original rego-fix



ER 8		ER 11/424 E		ER 16/426 E		ER 20/428 E	
Art.-Nr.	Spannbereich	Art.-Nr.	Spannbereich	Art.-Nr.	Spannbereich	Art.-Nr.	Spannbereich
108001	Satz / Set	111001	Satz / Set	116001	Satz / Set	120001	Satz / Set
		111002	Satz / Set	116002	Satz / Set	120002	Satz / Set
9 Stück/pcs. ø1-ø5		13 Stück/pcs. ø1-ø7		10 Stück/pcs. ø1-ø10		12 Stück/pcs. ø2-ø13	
108010	ø1,0 - 0,5	111010	ø1,0 - 0,5	116010	ø1,0 - 0,5	120010	ø1,0 - 0,5
108015	ø1,5 - 1,0	111015	ø1,5 - 1,0	116020	ø2,0 - 1,0	120020	ø2,0 - 1,0
108020	ø2,0 - 1,5	111020	ø2,0 - 1,5	116030	ø3,0 - 2,0	120030	ø3,0 - 2,0
108025	ø2,5 - 2,0	111025	ø2,5 - 2,0	116040	ø4,0 - 3,0	120040	ø4,0 - 3,0
108030	ø3,0 - 2,5	111030	ø3,0 - 2,5	116050	ø5,0 - 4,0	120050	ø5,0 - 4,0
108035	ø3,5 - 3,0	111035	ø3,5 - 3,0	116060	ø6,0 - 5,0	120060	ø6,0 - 5,0
108040	ø4,0 - 3,5	111040	ø4,0 - 3,5	116070	ø7,0 - 6,0	120070	ø7,0 - 6,0
108045	ø4,5 - 4,0	111045	ø4,5 - 4,0	116080	ø8,0 - 7,0	120080	ø8,0 - 7,0
108050	ø5,0 - 4,5	111050	ø5,0 - 4,5	116090	ø9,0 - 8,0	120090	ø9,0 - 8,0
		111055	ø5,5 - 5,0	116100	ø10,0 - 9,0	120100	ø10,0 - 9,0
		111060	ø6,0 - 5,5	ER 40/472 E		120110	ø11,0 - 10,0
		111065	ø6,5 - 6,0	140001	Satz / Set	120120	ø12,0 - 11,0
		111070	ø7,0 - 6,5	140002	Satz / Set	120130	ø13,0 - 12,0
ER 25/430 E		ER 32/470 E		23 Stück/pcs. ø3-ø26		ER 50/474 E	
125001	Satz / Set	132001	Satz / Set	140030	ø3,0 - 2,0	150001	Satz / Set
125002	Satz / Set	132002	Satz / Set	140040	ø4,0 - 3,0	12 Stück/pcs. ø10-ø34	
15 Stück/pcs. ø2-ø16		18 Stück/pcs. ø2-ø20		140050	ø6,0 - 5,0	150060	ø6,0 - 5,0
125010	ø1,0 - 0,5			140060	ø6,0 - 5,0	150080	ø8,0 - 6,0
125020	ø2,0 - 1,0	132020	ø2,0 - 1,0	140070	ø7,0 - 6,0	150100S	ø10,0 - 8,0
125030	ø3,0 - 2,0	132030	ø3,0 - 2,0	140080	ø8,0 - 7,0	150120	ø12,0 - 10,0
125040	ø4,0 - 3,0	132040	ø4,0 - 3,0	140090	ø9,0 - 8,0	150140	ø14,0 - 12,0
125050	ø5,0 - 4,0	132050	ø5,0 - 4,0	140100	ø10,0 - 9,0	150160	ø16,0 - 14,0
125060	ø6,0 - 5,0	132060	ø6,0 - 5,0	140110	ø11,0 - 10,0	150180	ø18,0 - 16,0
125070	ø7,0 - 6,0	132070	ø7,0 - 6,0	140120	ø12,0 - 11,0	150200	ø20,0 - 18,0
125080	ø8,0 - 7,0	132080	ø8,0 - 7,0	140130	ø13,0 - 12,0	150220	ø22,0 - 20,0
125090	ø9,0 - 8,0	132090	ø9,0 - 8,0	140140	ø14,0 - 13,0	150240	ø24,0 - 22,0
125100	ø10,0 - 9,0	132100	ø10,0 - 9,0	140150	ø15,0 - 14,0	150250	ø25,0 - 23,0
125110	ø11,0 - 10,0	132110	ø11,0 - 10,0	140160	ø16,0 - 15,0	150260	ø26,0 - 24,0
125120	ø12,0 - 11,0	132120	ø12,0 - 11,0	140170	ø17,0 - 16,0	150280	ø28,0 - 26,0
125130	ø13,0 - 12,0	132130	ø13,0 - 12,0	140180	ø18,0 - 17,0	150300	ø30,0 - 28,0
125140	ø14,0 - 13,0	132140	ø14,0 - 13,0	140190	ø19,0 - 18,0	150320	ø32,0 - 30,0
125150	ø15,0 - 14,0	132150	ø15,0 - 14,0	140200	ø20,0 - 19,0	150340	ø34,0 - 32,0
125160	ø16,0 - 15,0	132160	ø16,0 - 15,0	140210	ø21,0 - 20,0		
		132170	ø17,0 - 16,0	140220	ø22,0 - 21,0		
		132180	ø18,0 - 17,0	140230	ø23,0 - 22,0		
		132190	ø19,0 - 18,0	140240	ø24,0 - 23,0		
		132200	ø20,0 - 19,0	140250	ø25,0 - 24,0		
				140260	ø26,0 - 25,0		
				140270	ø27,0 - 26,0		
				140280	ø28,0 - 27,0		
				140290	ø29,0 - 28,0		
				140300	ø30,0 - 29,0		

Spannzangen DIN 6499 abgedichtet
für Werkzeuge mit Innenkühlung

Nur Nennmaßspannung

Collets DIN 6499 sealed
for tools with inner cooling systems

Only for nominal diameter

Lieferumfang ohne Werkzeug
Delivery without tool



ER 16 C		ER 20 C		ER 25 C		ER 32 C	
Art.-Nr.	Spannbereich	Art.-Nr.	Spannbereich	Art.-Nr.	Spannbereich	Art.-Nr.	Spannbereich
116001C	Satz / Set	120001C	Satz / Set	125001C	Satz / Set	132001C	Satz / Set
8 Stück/pcs. ø3-ø10		10 Stück/pcs. ø4-ø13		13 Stück/pcs. ø4-ø16		17 Stück/pcs. ø4-ø20	
116030C	ø3,0	120030C	ø3,0	125030C	ø3,0	132030C	ø3,0
116040C	ø4,0	120040C	ø4,0	125040C	ø4,0	132040C	ø4,0
116050C	ø5,0	120050C	ø5,0	125050C	ø5,0	132050C	ø5,0
116060C	ø6,0	120060C	ø6,0	125060C	ø6,0	132060C	ø6,0
116070C	ø7,0	120070C	ø7,0	125070C	ø7,0	132070C	ø7,0
116080C	ø8,0	120080C	ø8,0	125080C	ø8,0	132080C	ø8,0
116090C	ø9,0	120090C	ø9,0	125090C	ø9,0	132090C	ø9,0
116100C	ø10,0	120100C	ø10,0	125100C	ø10,0	132100C	ø10,0
		120110C	ø11,0	125110C	ø11,0	132110C	ø11,0
		120120C	ø12,0	125120C	ø12,0	132120C	ø12,0
		120130C	ø13,0	125130C	ø13,0	132130C	ø13,0
ER 40 C		ER 50 C		125140C	ø14,0	132140C	ø14,0
140001C	Satz / Set	150001C	Satz / Set	125150C	ø15,0	132150C	ø15,0
23 Stück/pcs. ø4-ø26		7 Stück/pcs. ø8-ø32*		125160C	ø16,0	132160C	ø16,0
140040C	ø4,0	150120C	ø12,0			132170C	ø17,0
140050C	ø5,0	150130C	ø13,0			132180C	ø18,0
140060C	ø6,0	150140C	ø14,0			132190C	ø19,0
140070C	ø7,0	150150C	ø15,0			132200C	ø20,0
140080C	ø8,0	150160C	ø16,0				
140090C	ø9,0	150170C	ø17,0				
140100C	ø10,0	150180C	ø18,0				
140110C	ø11,0	150190C	ø19,0				
140120C	ø12,0	150200C	ø20,0				
140130C	ø13,0	150210C	ø21,0				
140140C	ø14,0	150220C	ø22,0				
140150C	ø15,0	150230C	ø23,0				
140160C	ø16,0	150240C	ø24,0				
140170C	ø17,0	150250C	ø25,0				
140180C	ø18,0	150260C	ø26,0				
140190C	ø19,0	150270C	ø27,0				
140200C	ø20,0	150280C	ø28,0				
140210C	ø21,0	150290C	ø29,0				
140220C	ø22,0	150300C	ø30,0				
140230C	ø23,0	150310C	ø31,0				
140240C	ø24,0	150320C	ø32,0				
140250C	ø25,0	150330C	ø33,0				
140260C	ø26,0	150340C	ø34,0				
		* ø8, 10, 12, 16, 20, 25, 32					

Gewindebohrzangen rego-fix

Tapping collets rego-fix

Lieferumfang ohne Werkzeug
Delivery without tool



ER 16-GB		ER 25-GB		ER 32-GB		ER 40-GB	
Art.-Nr.	Schaft $\varnothing \times \square$	Art.-Nr.	Schaft $\varnothing \times \square$	Art.-Nr.	Schaft $\varnothing \times \square$	Art.-Nr.	Schaft $\varnothing \times \square$
GB116045	$\varnothing 4,5 \times 3,4$	GB125045	$\varnothing 4,5 \times 3,4$	GB132045	$\varnothing 4,5 \times 3,4$	GB140070	$\varnothing 7,0 \times 5,5$
GB116055	$\varnothing 5,5 \times 4,3$	GB125055	$\varnothing 5,5 \times 4,3$	GB132055	$\varnothing 5,5 \times 4,3$	GB140080	$\varnothing 8,0 \times 6,2$
GB116060	$\varnothing 6,0 \times 4,9$	GB125060	$\varnothing 6,0 \times 4,9$	GB132060	$\varnothing 6,0 \times 4,9$	GB140090	$\varnothing 9,0 \times 7,0$
GB116070	$\varnothing 7,0 \times 5,5$	GB125070	$\varnothing 7,0 \times 5,5$	GB132070	$\varnothing 7,0 \times 5,5$	GB140100	$\varnothing 10,0 \times 8,0$
	ER 20-GB	GB125080	$\varnothing 8,0 \times 6,2$	GB132080	$\varnothing 8,0 \times 6,2$	GB140110	$\varnothing 11,0 \times 9,0$
GB120045	$\varnothing 4,5 \times 3,4$	GB125090	$\varnothing 9,0 \times 7,0$	GB132090	$\varnothing 9,0 \times 7,0$	GB140120	$\varnothing 12,0 \times 9,0$
GB120055	$\varnothing 5,5 \times 4,3$	GB125100	$\varnothing 10,0 \times 8,0$	GB132100	$\varnothing 10,0 \times 8,0$	GB140140	$\varnothing 14,0 \times 11,0$
GB120060	$\varnothing 6,0 \times 4,9$	GB125110	$\varnothing 11,0 \times 9,0$	GB132110	$\varnothing 11,0 \times 9,0$	GB140160	$\varnothing 16,0 \times 12,0$
GB120070	$\varnothing 7,0 \times 5,5$	GB125120	$\varnothing 12,0 \times 9,0$	GB132120	$\varnothing 12,0 \times 9,0$	GB140180	$\varnothing 18,0 \times 14,5$
GB120080	$\varnothing 8,0 \times 6,2$			GB132140	$\varnothing 14,0 \times 11,0$	GB140200	$\varnothing 20,0 \times 16,0$
GB120090	$\varnothing 9,0 \times 7,0$			GB132160	$\varnothing 16,0 \times 12,0$	GB140220	$\varnothing 22,0 \times 18,0$
GB120100	$\varnothing 10,0 \times 8,0$						

Gewindebohrzangen PCM ET1 mit Längenausgleich

Tapping collets PCM ET1 with compensation

Lieferumfang ohne Werkzeug
Delivery without tool



ET1-16		ET1-20		ET1-25		ET1-32		ET1-40	
Art.-Nr.	Schaft	Art.-Nr.	Schaft	Art.-Nr.	Schaft	Art.-Nr.	Schaft	Art.-Nr.	Schaft
ET1-16280	$\varnothing 2,8$	ET1-20280	$\varnothing 2,8$	ET1-25280	$\varnothing 2,8$	ET1-32450	$\varnothing 4,5$	ET1-40600	$\varnothing 6,0$
ET1-16300	$\varnothing 3,0$	ET1-20300	$\varnothing 3,0$	ET1-25300	$\varnothing 3,0$	ET1-32500	$\varnothing 5,0$	ET1-40700	$\varnothing 7,0$
ET1-16350	$\varnothing 3,5$	ET1-20350	$\varnothing 3,5$	ET1-25350	$\varnothing 3,5$	ET1-32550	$\varnothing 5,5$	ET1-40800	$\varnothing 8,0$
ET1-16400	$\varnothing 4,0$	ET1-20400	$\varnothing 4,0$	ET1-25400	$\varnothing 4,0$	ET1-32600	$\varnothing 6,0$	ET1-40850	$\varnothing 8,5$
ET1-16450	$\varnothing 4,5$	ET1-20450	$\varnothing 4,5$	ET1-25450	$\varnothing 4,5$	ET1-32700	$\varnothing 7,0$	ET1-40900	$\varnothing 9,0$
ET1-16500	$\varnothing 5,0$	ET1-20500	$\varnothing 5,0$	ET1-25500	$\varnothing 5,0$	ET1-32800	$\varnothing 8,0$	ET1-40100	$\varnothing 10,0$
ET1-16550	$\varnothing 5,5$	ET1-20550	$\varnothing 5,5$	ET1-25550	$\varnothing 5,5$	ET1-32850	$\varnothing 8,5$	ET1-40105	$\varnothing 10,5$
ET1-16600	$\varnothing 6,0$	ET1-20600	$\varnothing 6,0$	ET1-25600	$\varnothing 6,0$	ET1-32900	$\varnothing 9,0$	ET1-40110	$\varnothing 11,0$
		ET1-20700	$\varnothing 7,0$	ET1-25700	$\varnothing 7,0$	ET1-32100	$\varnothing 10,0$	ET1-40120	$\varnothing 12,0$
				ET1-25800	$\varnothing 8,0$	ET1-32105	$\varnothing 10,5$	ET1-40125	$\varnothing 12,5$
				ET1-25850	$\varnothing 8,5$	ET1-32110	$\varnothing 11,0$	ET1-40140	$\varnothing 14,0$
				ET1-25900	$\varnothing 9,0$	ET1-32120	$\varnothing 12,0$	ET1-40150	$\varnothing 15,0$
				ET1-25100	$\varnothing 10,0$	ET1-32125	$\varnothing 12,5$	ET1-40160	$\varnothing 16,0$
								ET1-40170	$\varnothing 17,0$

TOOLFIX Werkzeugmontagegerät TOOLFIX mounting equipment		Art.-Nr.	Typ	SK	
		250410	SK 30	30	
		251410	SK 40	40	
		252410	SK 50	50	
		VDI			
		259410	VDI 20	20	
		260410	VDI 30	30	
		261410	VDI 40	40	
		262410	VDI 50	50	
		HSK			
		253410	HSK-A40	A40	
		254410	HSK-E40	E40	
		255410	HSK-A50	A50	
		257410	HSK-A63	A63	
		258410	HSK-E63	E63	
		POLYGON			
		263410	C4	C4	
		264410	C5	C5	
		265410	C6	C6	
266410	C8	C8			

TOOLFIX VARIO Adaptersystem



VARIO ist die Version mit Schnellwechselfverschluss zum Auswechseln von verschiedenen Werkzeugadaptern. Die VARIO-Version bietet Anwendern von verschiedenen Werkzeugaufnahmen die Möglichkeit verschiedene Adapterformen auf einem Basiskörper zu verwenden.

VARIO is a version with quick change lock for changing different tool adaptors. The VARIO-version makes possible to use different forms of adaptors on the same base-body for users with different toolholders.

Art.-Nr.	Typ	Art.-Nr.	Typ
31000	TOOLFIX VARIO Basiskörper / Base-body		
SK		HSK	
31030	VARIO-Adapter 30	31232	VARIO-Adapter A 32
31040	VARIO-Adapter 40	31240	VARIO-Adapter A 40
31050	VARIO-Adapter 50	31250	VARIO-Adapter A 50
VDI		31263	VARIO-Adapter A 63
31116	VARIO-Adapter 16	31280	VARIO-Adapter A 80
31120	VARIO-Adapter 20	31210	VARIO-Adapter A100
31125	VARIO-Adapter 25	31632	VARIO-Adapter E 32
31130	VARIO-Adapter 30	31640	VARIO-Adapter E 40
31140	VARIO-Adapter 40	31650	VARIO-Adapter E 50
31150	VARIO-Adapter 50	31663	VARIO-Adapter E 63
		POLYGON	
		31803	VARIO-Adapter C 3
		31804	VARIO-Adapter C 4
		31805	VARIO-Adapter C 5
		31806	VARIO-Adapter C 6
		31808	VARIO-Adapter C 8



Steilkegel-Werkzeugaufnahmen DIN 2080 DIN 69871 MAS BT

ISO Taper-toolholders
DIN 2080 DIN 69871 MAS BT



ETS16



ETS16C



ER16



ER16C



MAS BT15 - BT30

