

Steilkegel-Werkzeugaufnahmen S20T
für Tsugami Bearbeitungszentrum VA1-II
ISO Taper-toolholders S20T
for Tsugami machining centre VA1-II



Katalog Nr. 16111
Catalogue No. 16111



Typ S20T



Spannzangenfutter für Spannzangen DIN 6499 + ETS Collet chuck for collets DIN 6499 + ETS

Rundlaufgenauigkeit Steilkegel zu Werkzeugaufnahme < 0,005
Concentricity from the taper to the holding part < 0,005

gewuchtet G 2,5 - 30.000 U/min. oder U < 1 gmm
balanced G 2,5 - 30.000 r.p.m. or U < 1 gmm

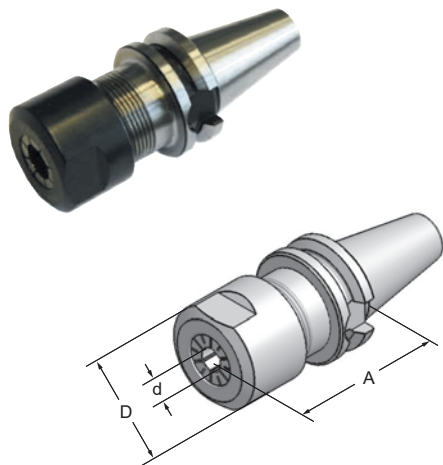

Tsugami S20T

Art.-Nr.	Typ	A	d	D
20.05.07.20	S20TxER11x40	40	0,5- 7	19
20.05.07.2	S20TxER11x50	50	0,5- 7	19
20.05.10.20M	S20TxER16mx40	40	0,5-10	25
20.05.10.20E	S20TxETS16x40	40	0,5-10	25
20.05.13.20M	S20TxER20mx40	40	1-13	28

Zylinderschaftaufnahme Weldon DIN 1835 B Holder for straight shank tools Weldon DIN 1835 B

Rundlaufgenauigkeit Steilkegel zu Werkzeugaufnahme < 0,005
Concentricity from the taper to the holding part < 0,005

gewuchtet G 6,3 - 30.000 U/min. oder U < 1 gmm
balanced G 6,3 - 30.000 r.p.m. or U < 1 gmm

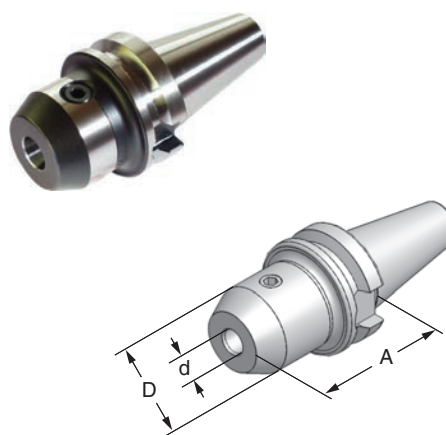

Tsugami S20T

Art.-Nr.	Typ	A	d	D
20.05.06.6	S20Txø06x50	50	6	25
20.05.08.6	S20Txø08x50	50	8	28
20.05.10.6	S20Txø10x50	50	10	35
20.05.12.6	S20Txø12x50	50	12	42

Messerkopfaufnahme DIN 6357 Shell mill adaptor for facing cutters DIN 6357

Rundlaufgenauigkeit Steilkegel zu Werkzeugaufnahme < 0,005
Concentricity from the taper to the holding part < 0,005

gewuchtet G 6,3 - 30.000 U/min. oder U < 1 gmm
balanced G 6,3 - 30.000 r.p.m. or U < 1 gmm

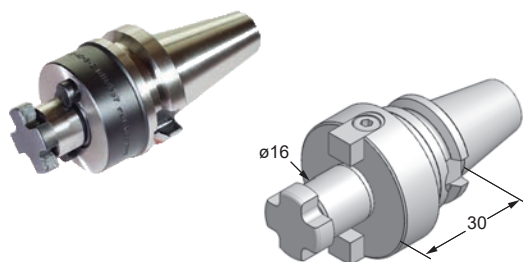

Schlüssel DIN 6368 Key DIN 6368



Tsugami S20T

Art.-Nr.	Typ
20.05.16.9	S20Tx16x30-AD
170101	Schlüssel DIN 6368 - ø16

Anzugsbolzen Retention knob

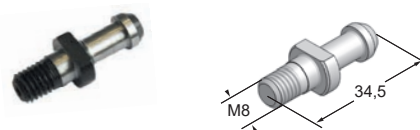

Art.-Nr.	Typ
20.08.42	BT20x90°

Spannschlüssel Key



Art.-Nr.	SW	für Spannmutter
911180	17	ER11
916162	22	ER16m
916163	24	ETS16
920160	E 20 mini	ER20m