

Bohrstangenhalter Form E2
 Boring bar holder form E2

Kühlmittelezufuhr intern + extern
 Coolant supply internal + external

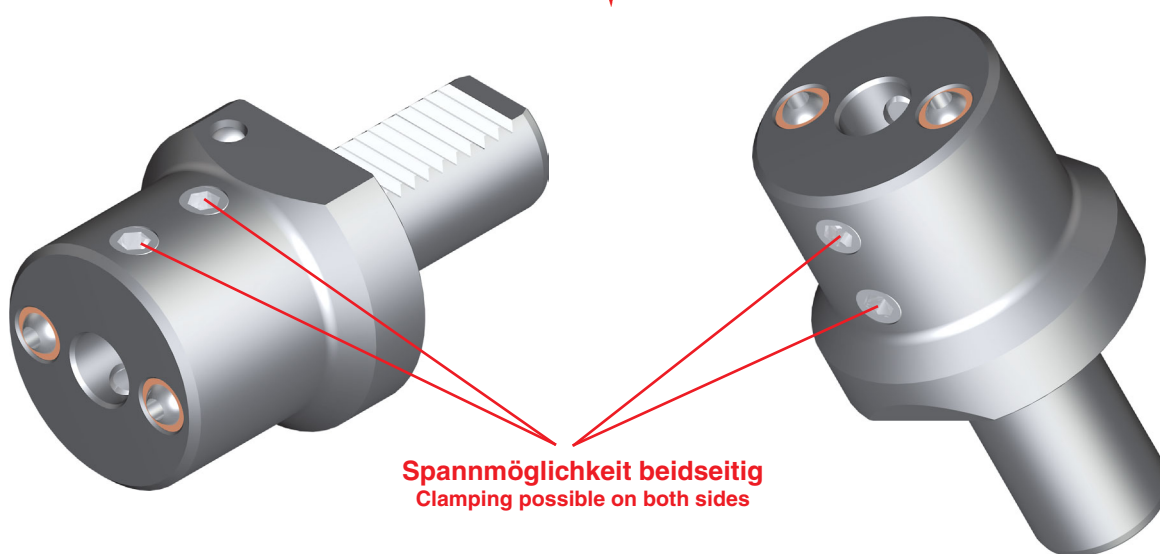

Spannmöglichkeit beidseitig
 Clamping possible on both sides

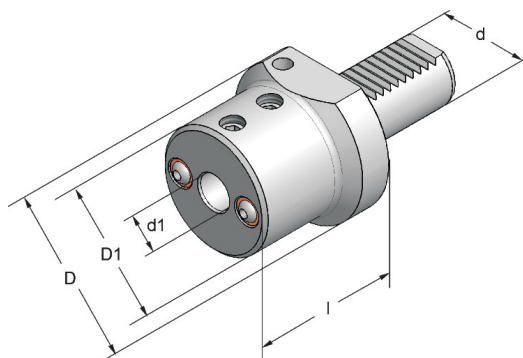

VDI 30

l1 = Bohrungstiefe l1 = drill depth

VDI 40

Art.-Nr.	Typ	d	d1	D	D1	l	l1	Art.-Nr.	Typ	d	d1	D	D1	l	l1
30.10.290-2	E2-30x10x60	30	10	68	50	60	106	40.08.290-2	E2-40x08x75	40	08	83	50	75	130
30.12.290-2	E2-30x12x60	30	12	68	50	60	106	40.10.290-2	E2-40x10x75	40	10	83	50	75	130
30.16.290-2	E2-30x16x60	30	16	68	55	60	106	40.12.290-2	E2-40x12x75	40	12	83	50	75	130
30.20.290-2	E2-30x20x60	30	20	68	55	60	55	40.16.290-2	E2-40x16x75	40	16	83	55	75	130
30.25.290-2	E2-30x25x60	30	25	68	55	60	55	40.20.290-2	E2-40x20x75	40	20	83	55	75	130
30.32.290-2	E2-30x32x60	30	32	68	68	60	57	40.25.290-2	E2-40x25x75	40	25	83	60	75	66
								40.32.290-2	E2-40x32x75	40	32	83	72	75	66
								40.40.290-2	E2-40x40x85	40	40	83	83	85	73