

Werkzeughalter für CNC-Drehmaschinen
 DIN 69880 / DIN ISO 10889
 Toolholders for CNC machines
 DIN 69880 / DIN ISO 10889

VDI 16

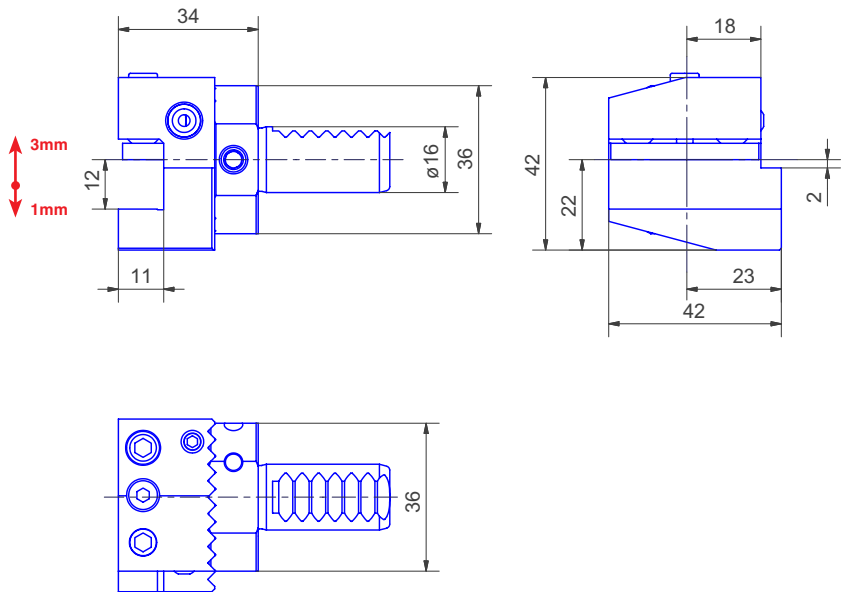

VDI 16 Radial-Werkzeughalter Form B1 höhenverstellbar
 VDI 16 Radial toolholder Form B1 adjustable in height



Art.-Nr.	Typ
16.12.061	B1-16x12x34

VDI 16 Radial-Werkzeughalter Form B3 höhenverstellbar
 VDI 16 Radial toolholder Form B3 adjustable in height

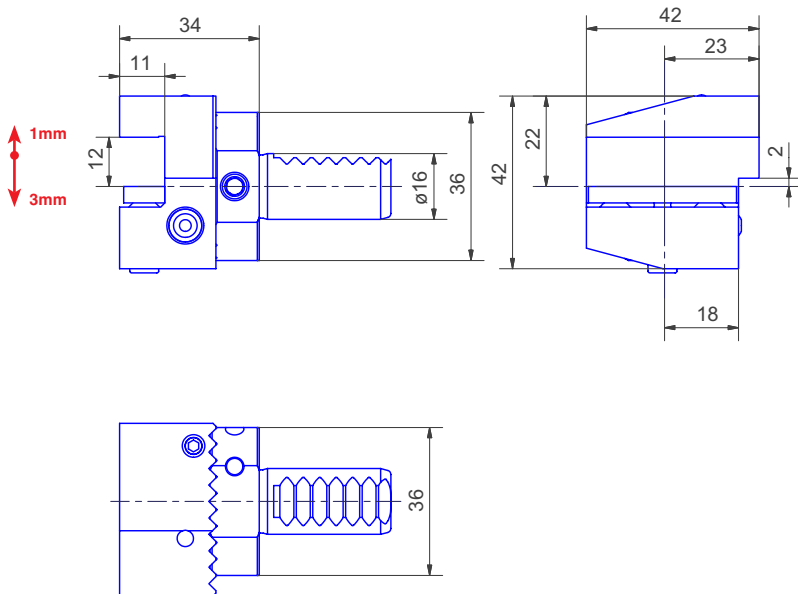
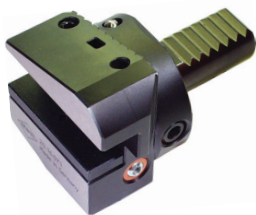

Art.-Nr.	Typ
16.12.071	B3-16x12x34

